

Convotherm mini easyTouch Combi Steamer

CMINIT10.10 / CMINT10.10B ELECTRIC DIRECT STEAM 10 X 1/1 GN

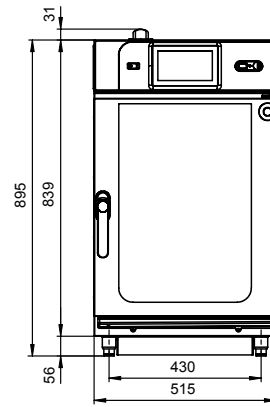

Front view



Side view

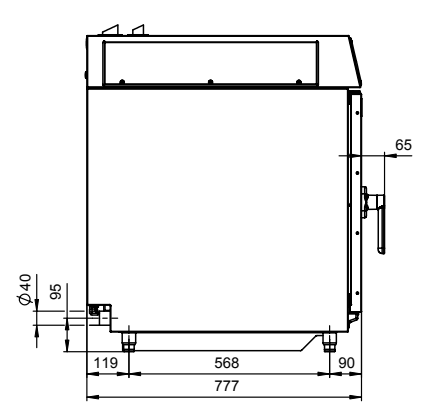

View from above with wall clearances

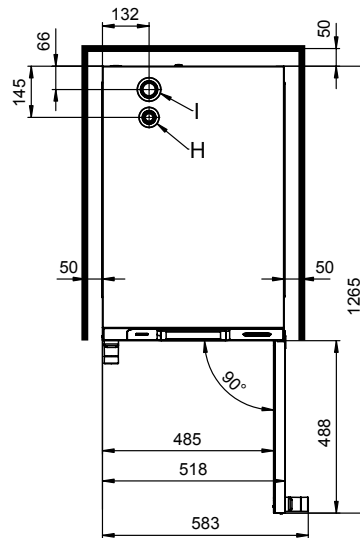

- A** Water supply connection (for water injection)
- B** Water supply injection (for cleaning)
- C** Drain connection DN 40
- D** Electrical connection
- E** Equipotential bonding
- F** Rinse aid connection
- G** Cleaning agent connection
- H** Air vent Ø 30 mm
- I** Dry air intake Ø 43 mm
- M** Safety overflow 60 mm x 20 mm
- N** RJ45 Ethernet port
- P** mini Condensation Hood Pro - optional
- Q** Safety thermostat reset

- Direct steam system
- Requires minimum space - fits anywhere, saving expensive floor space
- Natural Smart Climate™ (ACS+) cooking methods: Steam, Combi-steam, Convection
- Natural Smart Climate™ extra functions:
 - Crisp&Tasty - 3 moisture removal settings
 - HumidifyPro - 3 humidity settings
 - BakePro - 3 levels of traditional baking
 - Reduced fan speed and auto-reverse mode
- easyTouch 7" TFT HiRes glass touch display (capacitive)
- ConvoClean+ fully automatic cleaning system with 3 intensity levels and express mode
- Hand shower
- Right-hinged appliance door

DIMENSIONS

Width	515 mm
Depth	777 mm
Height	895 mm
Weight	70 kg

PACKED DIMENSIONS

Width	580 mm
Depth	910 mm
Height	1085 mm
Weight (including cleaning system)	83 kg

Safety clearances

Rear	50 mm
Right	50 mm
Left	50 mm
(larger recommended for servicing)	
Top (for ventilation)	500 mm

INSTALLATION REQUIREMENTS

Appliance must be installed level. Do not install the appliance near, above or below a source of heat or near flammable surfaces

LOADING CAPACITY

Shelf distance	40mm
GN 1/1 shelves (40mm deep)	10

ELECTRICAL SUPPLY

3N~400-415V ~50/60Hz (3P+N+E)
 Connected load 10.5 kW
 Rated current 15.7 A
 Fit main switch (all-pin-circuit-breaker) on site, in close proximity to the appliance. Connection for potential compensation.

WATER CONNECTION

Water supply
 Cold water R3/4" 2 - 6 bar flow pressure
 Fit water tap and dirt filter on site in close proximity to appliance. Backflow prevention valve (supplied)

WATER QUALITY

Drinking water
 Overall hardness 70-125 ppl
Properties
 pH 6.5 - 8.5
 Cl⁻ (chloride) max. 60 mg/l
 Cl₂ (free chlorine) max. 0.2 mg/l
 SO₄²⁻ (sulphate) max. 150 mg/l
 Fe (iron) max. 0.1 mg/l
 Electrical conductivity min 20 µS/cm

Water outlet

R40, fixed connection or funnel siphon

EMISSIONS

Heat output
 Latent heat 1000 KJ/h
 Sensible heat 1100 KJ/h
Noise during operation max. 70 dBA
 Spray guard 1Px4

Rear view

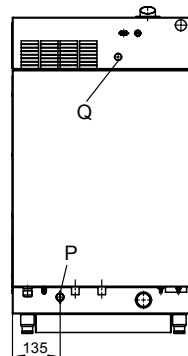

Connection positions in appliance floor

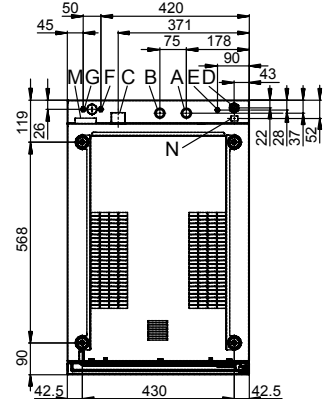

Australia moffat.com.au
 New Zealand moffat.co.nz



In line with policy to continually develop and improve its products, Moffat Limited reserves the right to change specifications and design without notice.

an Ali Group Company



The Spirit of Excellence