

CD120

RACK CONVEYOR OPERATOR MANUAL



WASHTECH[®]
PROFESSIONAL WASH SYSTEMS

Warnings



Before installation and commissioning, you must read the safety instructions and warnings carefully and all the warning labels attached to the equipment.

Equipment contains dangerous voltages and can be hazardous if installed or operated incorrectly. Non-compliance with warnings or failure to follow the instructions contained in this manual can result in loss of life, severe personal injury or serious damage to property.

Before installation or repair, you must read the instructions and warnings carefully and all the warning labels attached to the equipment.

All service/repair work must be carried out by qualified personnel only and ensure compliance with all local codes and standards including AS/NZS 3500.1.

Important Information



Failure to comply (even partially) with the instructions given in this manual will invalidate the product warranty and relieves the manufacturer of any responsibility.

The alteration of machine operation, design or the replacement of parts not approved by the manufacturer may void warranties and approvals.

This machine is intended for commercial use only.

This machine is designed for the cleaning of fresh food waste from crockery, cutlery, containers and food preparation and manufacturing equipment. Consult the manufacturer regarding suitability of the machine for other applications. It is not a waste disposal unit, and it is essential that significant loose soil or waste is removed from washware by pre-rinsing or scraping, before it is placed in the machine.

The information contained in this document is checked, reviewed and updated regularly to ensure that it is accurate and relevant to the model described. However discrepancies and errors can occur. We welcome your feedback.

Document subject to change without prior notice.

Information supplied in this manual is copyright. No part of this work may be reproduced or copied in any form or by any means, electronic or mechanical without the express permission of Washtech.

Contents

2. Warning
3. Contents
4. Safety Instructions
5. Installation Diagram
6. Installation Instructions
8. Installation Checklist
9. Installation Troubleshooting
10. Operator Use Guide
11. Operator Care – Wash Zone
12. Operator Care – Curtains
13. Operator Troubleshooting
14. Schematic Diagram
15. Accessories



Safety Instructions

Installation

- Use qualified, skilled personnel.
- Follow installation instructions.
- Connect to correct voltage and supply current.
- Provide fully accessible Electrical Isolation Switch & water supply valves.

Training and Supervision

- Read and Understand the Operating instructions and train all staff.
- This appliance must not be operated by children or infirm persons.
- Machine panels must only be removed by suitably qualified and trained personnel – internal hazards include live electrics and very hot surfaces.
- No part of this appliance is not intended for use as a stepladder – do not stand on open door.

Hot Surfaces

- Some surfaces may be hot or very hot.

Chemicals

- Commercial dishwashing detergents are hazardous – handle with care.
- Read and follow the safety information found on the labels of detergent containers and Material Safety Data Sheets.
- Use protective eyewear and clothing if decanting containers.

Hot Water

- Do not put hands in wash water which may be over 60°C and contain hazardous caustic detergent.
- Rinse water can be over 90°C.
- Door safety switches are designed for emergency use only.

Cleaning

- Do not hose down the machine or splash water over the exterior.
- Watch for broken glass etc. when cleaning the inside of the machine.

Warnings



Equipment contains dangerous voltages and can be hazardous if installed or operated incorrectly. Non-compliance with Warnings or failure to follow the instructions contained in this manual can result in loss of life, severe personal injury or serious damage to property.

Installation and servicing must be carried out by a suitably qualified person in compliance with all local codes and standards including AS/NZS 3500.1.

Installation Diagram

CD120L Installation

- Part #: CD120L
- Date: 22-04-2022
- Version: 3-A

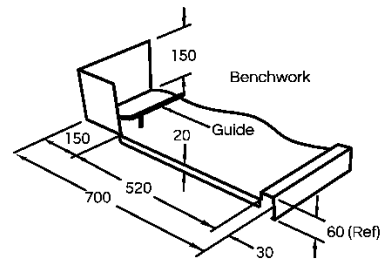
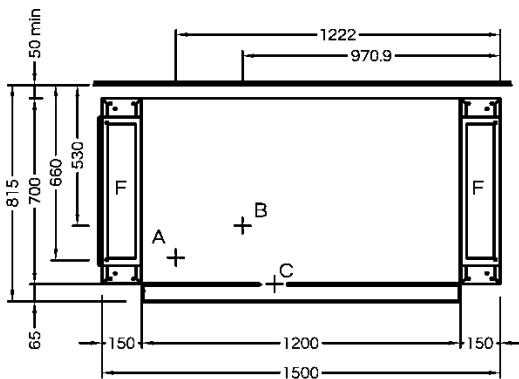
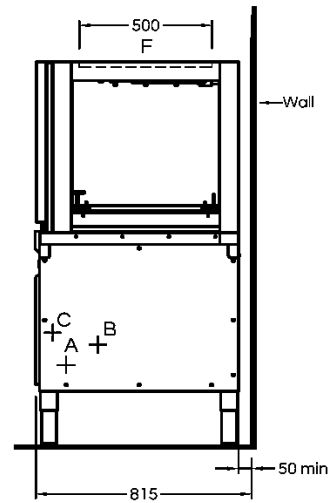
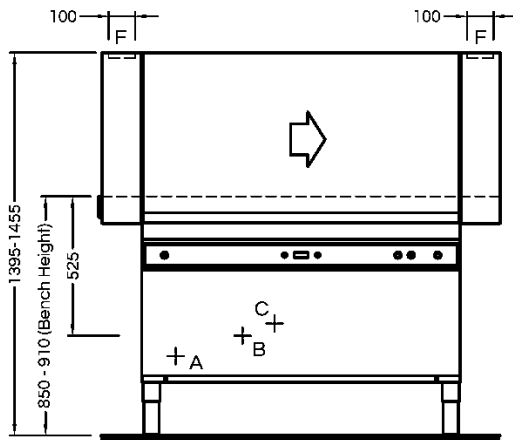

Services

A	Hot water 65°C (DVC supplied)	200-350 kPa	3/4"
B	Waste - tank drainage point	2" BSP	50mm
C	Electrical connection	400-415V, 50Hz, 3P+N+E	25A ₃
F	Extraction - Consult with ventilation engineer. Allow for steam. Total extraction rate typically required for duct connections		15m ³ /min (250l /sec)

Note: Isolating switch must be within 1m of, and not directly behind the machine. Isolating water valve must be readily accessible

Installation Instructions

Machine Positioning

- Unpack machine, check for damage and complete delivery.
- Install machine on sound waterproof self-draining floor and use adjustable feet to level machine.



NOTE: Failure to level the machine correctly may result in leaking during the cycle, overflowing from the door sill, poor hygiene through the wash tank not being able to drain correctly, and/or visibly uneven door.

- Allow room for detergent to one side of machine or in adjacent cupboard. 20 litre container requires approximately 450H x 250W x 350D, but smaller containers are available from many suppliers.

Ventilation

- 15 m³/min = 250 l/sec – refer installation diagram – extraction via connected ducts or overhead canopy.

Inlet Water Operation

Incoming water should be within the following standard requirements:

- Temperature: 65 °C.
- Connection: 20 mm (3/4" BSP) male.



NOTE: Flush supply line before connection. Poor quality supply or excessive water hardness may affect performance or damage machine – filtration and/or softening is recommended.

- Flow rate: minimum 20 litres per minute.
- Water Consumption: 5 litres per minute.
- Pressure: between 200 and 350 kPa.



NOTE: This machine is not equipped with a rinse booster pump as standard and does rely on incoming water pressure to drive the rinse cycle.

NOTE: If above 350 kPa fit pressure limiter valve (LPV). Do not use small diameter plastic supply lines.

- Backflow prevention: Dual Check Valve (DCV) fitted standard.

Water Quality Requirements

The incoming water should also be within the following parameters:



Hardness	ppm	pH
min	20	7
max	100	8

Ions	Cl ⁻	SO ₄	Fe	Mn	Cu	Cl ₂
Max mg/L	100	400	0.1	0.5	0.05	0.1

NOTE: Levels above or below the stated requirements can be expected to increase component wear and reduce the expected useful life of the dishwasher. If in doubt, it is best to consult a water specialist and have the incoming water professionally tested and treated if necessary.

Installation Instructions

Power

- Electrical supply required is 3p/25A 415V 50Hz via switched outlet adjacent to machine.
 NOTE: Equipment contains dangerous voltages and can be hazardous if installed or operated incorrectly. Non-compliance with warnings or failure to follow the instructions contained in this manual can result in loss of life, severe personal injury or serious damage to property.

Chemical

- Detergent and rinse aid pumps are not supplied with the CD100. We recommend you consult your chemical supplier and/or a local chemical expert for their recommended detergent and Rinse Fluid injector pumps.



NOTE: Commercial detergents can be hazardous – read instructions, store safely and handle with care. Care needs to be taken when changing chemicals, ensuring that the detergent is not accidentally connected to the rinse fluid inlet line.

NOTE: If uncertain, please consult a chemical specialist for assistance in selecting the right chemicals and calibrating machine settings to suit this along with your unique site conditions and requirements.

Waste

- 40mm connection required to point B as specified on install diagram. An S-trap must be fitted on each of these points.



NOTE: Either copper or P.V.C. may be used for the waste connection – P.V.C. is more resistant to some harsh detergents. Some authorities however suggest that copper is required because the machine rinses at up to 90°C. It is important to note that rinse water mixes with the 65°C wash water before discharge and then flows into the sink trap where the water is further cooled before entering the drainage plumbing. We recommend consulting your local authority to ensure your site remains compliant.

Installation Checklist

- Complete attached Installation Checklist to ensure machine is installed and running correctly, and operator is familiar with operating procedures.

Installation Checklist

Check	Notes
DELIVERY	
SUPPLIED COMPLETE?	<input type="checkbox"/> CHECK THERE HAS NOT BEEN ANY TRANSIT DAMAGE
POSITION	
LEVEL AND STABLE?	<input type="checkbox"/> ON SOUND, WATERPROOF, SELF-DRAINING FLOOR
WATER	
ISOLATOR VALVE FITTED?	<input type="checkbox"/> ACCESSIBLE, ALL FITTINGS SOUND, AND NO LEAKS
TEMPERATURE CORRECT	<input type="checkbox"/> HOT WATER INLET 65 °C
PRESSURE CORRECT (200 – 350 kPa)?	<input type="checkbox"/> LIMITER FITTED IF ABOVE RANGE, RINSE PUMP IF BELOW
FLOW RATE CORRECT (> 20L per min)?	<input type="checkbox"/> RINSE PUMP FITTED IF BELOW REQUIREMENT
QUALITY WITHIN REQUIREMENTS?	<input type="checkbox"/> FILTER OR SOFTENER IN PLACE IF OUTSIDE REQUIREMENTS
POWER	
ISOLATING SWITCH (3p/25A 415V 50Hz)?	<input type="checkbox"/> FITTED, FUNCTIONAL AND ACCESSIBLE
CORRECT SUPPLY	<input type="checkbox"/> VOLTAGE, CURRENT, CIRCUIT BREAKER ALL CORRECT
WASTE	
CONNECTION TO 50mm PIPE?	<input type="checkbox"/> CORRECT CONNECTION TO PLUMBING
SUITABLE AIR GAP?	<input type="checkbox"/> REFER OPERATOR MANUAL
CHEMICALS	
	CHEMICAL NAME CONTAINER NO LEAKS PRIMED CALIBRATED
DETERGENT	<input type="checkbox"/> <input type="checkbox"/> <input type="checkbox"/> <input type="checkbox"/> <input type="checkbox"/>
RINSE FLUID	<input type="checkbox"/> <input type="checkbox"/> <input type="checkbox"/> <input type="checkbox"/> <input type="checkbox"/>
MACHINE OPERATION	
MACHINE RUNNING CORRECTLY?	<input type="checkbox"/> MULTIPLE CYCLES RUN, NO ISSUES
CHEMICAL DOSAGE CORRECT?	<input type="checkbox"/> CORRECTLY FLOWING INTO MACHINE, NO FOAMING
ALL OPERATIONS CORRECT?	<input type="checkbox"/> FILL LEVEL CORRECT, NO DRAINAGE ISSUES
OPERATOR TRAINING	
ENSURE THAT THE CUSTOMER HAS BEEN GIVEN THE OPERATION MANUAL AND WALL CHART, AND IS AWARE OF THE IMPORTANCE OF BOTH USING AND CLEANING THE MACHINE CORRECTLY	
START UP	<input type="checkbox"/>
PRE-RINSE AND RACKING	<input type="checkbox"/> BETTER TO RINSE PLATES THAN REMOVE WASTE FROM MACHINE
MACHINE USE AND CYCLE SELECTION	<input type="checkbox"/> USE LONG CYCLE WHERE POSSIBLE
DRAINING THE MACHINE	<input type="checkbox"/> DRAIN THE MACHINE DAILY
SHUT-DOWN AND DAILY CLEANING	<input type="checkbox"/> CHECK WASH ELEMENTS HAVE COOLED BEFORE CLEANING
WEEKLY MAINTENANCE	<input type="checkbox"/> FULL MACHINE CLEAN INCLUDING WASH/RINSE ARMS
PLANNED SERVICNG	<input type="checkbox"/> IMPORTANCE OF HAVING MACHINE SERVICED REGULARLY

Installation Troubleshooting

Machine not starting or filling

- Ensure water supply to machine is turned on.
- Ensure power supply to machine is turned on.
- Check that the water inlet hose isn't twisted or kinked.

Poor wash results

- Check that there are adequate pre-rinse processes in place.
- Ensure high quality non-foaming commercial dishwasher detergent has been connected at the correct dosage for your site, water quality and application. If uncertain, [consult a chemical specialist](#).
- Ensure that the wash temperature is between 60°C and 65°C.

Chemical residue on items after the cycle

- Check water pressure, this is likely too low and below the minimum 200kPa required.
- Check that nothing is obstructing the wash & rinse arms.
- Check the rinse fluid dosage is not too high. If uncertain, please [consult a chemical specialist](#).

Dishwasher is foaming

- Ensure high quality non-foaming commercial dishwasher detergent has been connected at the correct dosage for your site and application. If uncertain, please [consult a chemical specialist](#).
- Allow wash water to heat to at least 60 °C prior to starting the first cycle as some commercial dishwasher chemical will foam at low temperatures.
- Low water pressure can result in above average detergent concentrations. As low water pressure also impacts rinse results, we recommended this is solved by installing a rinse pump rather than compensating by reducing chemical dosages.

Other equipment in the kitchen has needed filters or has scale

- Due to the high temperatures in dishwashers, scale will build up in the wash tank, on the arms and in the rinse tank. The incoming water should be treated. If uncertain, please [consult a water specialist](#).
- As with the Combi-Oven, high chloride levels will do irreversible damage to a number of the components inside a commercial dishwasher. The incoming water should be appropriately treated. If uncertain, please [consult a water specialist](#).

Pawl drive not operating

- Clear the area around the limit switch on the roller table.
- Adjust the clutch tension of the Pawl Drive motor, the Pawl drive clutch tension can be tightened by turning the 2 nuts at the bottom of the pawl drive shaft clockwise or loosened by turning the 2 nuts anticlockwise.

(Note: the tension must be at a level where a person can grab the pawl drive with both hands and stop the pawl drive motion).

Grinding noise escaping from the machine

- Wash pump rotation must be checked after installation to ensure correct direction (excessive noise and damage with incorrect direction).

Machine stops and refills during the commissioning stage

- Fit the curtains according to the Operator Care – curtain diagram (page 14).
- Ensure the Scrap Trays are fitted in the Wash and Rinse Zones.

Operator Use Guide



START

- Turn on at wall.
- Fit Wash Pump Inlet Filter.
- Fit Drain Upstand.
- Fit Scrap Trays .
- Shut all doors and turn wall and Machine Power on.
- Machine begins filling. Full light amber when tank is full.
- Ready light glows amber when the machine is up to required temperature.

OPERATION

- Press Start button to operate machine.
- Start button glows green while machine operates.
- Stack a rack with items and push into the inlet zone of the machine.

NOTE: Pumps and conveyor will stop operating if the machine is left idle for 2 minutes. To restart the pump and conveyor simply feed a new rack into the inlet of the machine.

SHUT DOWN – END OF EACH DAY

- Press Stop button.
- Take out Drain Upstand to gravity drain the machine.
- When tank is visibly empty switch Power button off.
- Proceed with Operator Care Wash Zone cleaning instructions.

SUGGESTED BEST PRACTICE

- | | |
|-----------|---|
| Pre-rinse | Scrape and/or rinse trays, plates & glasses in cool water. |
| Chemical | Use a good quality non foaming commercial detergent and drying agent – do not use domestic detergents which will cause the machine to foam. |

Operator Care – Wash Zone

CD120 Wash Zone

- Part #: CD120 Wash Zone
- Date: 22/04/2022
- Version: 1-A

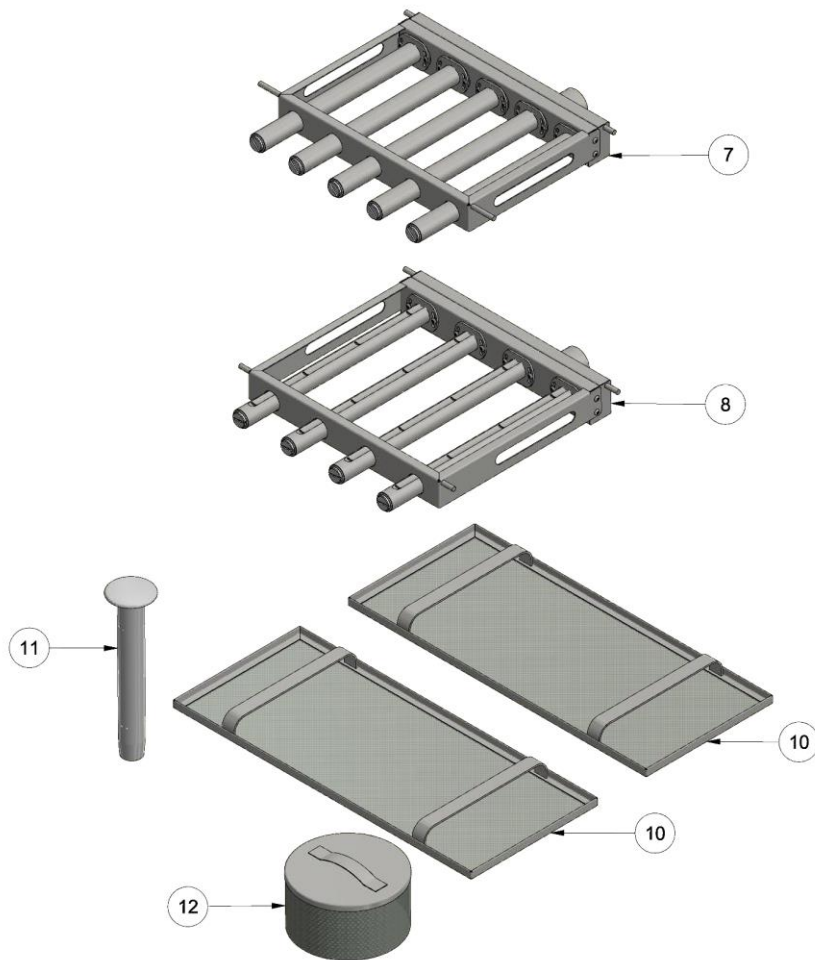

Daily Cleaning

- Remove Scrap Trays (10) and clean with a brush and water to clear grid.
- Remove Wash Pump Inlet Filter (12) and clean with a brush and water to clear grid.
- Return Drain Upstand (11), Wash Pump Inlet Filter (12) and Scrap Trays (10) to the machine.

Weekly Cleaning

- To be done in conjunction with Daily cleaning.
- Remove Lower Wash Arms (8) – lift up to unhook the arm and then withdraw.
- Remove Upper Wash Arms (7) – push the clip up and then withdraw.
- Check to ensure arms are clear of obstructions. Remove end caps to clear if not.
- Flush Arms (7 & 8) with water. Use a toothpick or paper clip if necessary to clear jets.
- Return the Wash Pump Inlet Filter (12), the Drain Plug (11), Scrap Trays (10), Lower Wash Arms (8) and Upper Wash Arms (7) to the machine.

Operator Care - Curtains

CD120L Curtains

- Part #: CD120L CURTAINS
- Date: 01/042022
- Version: 1-A

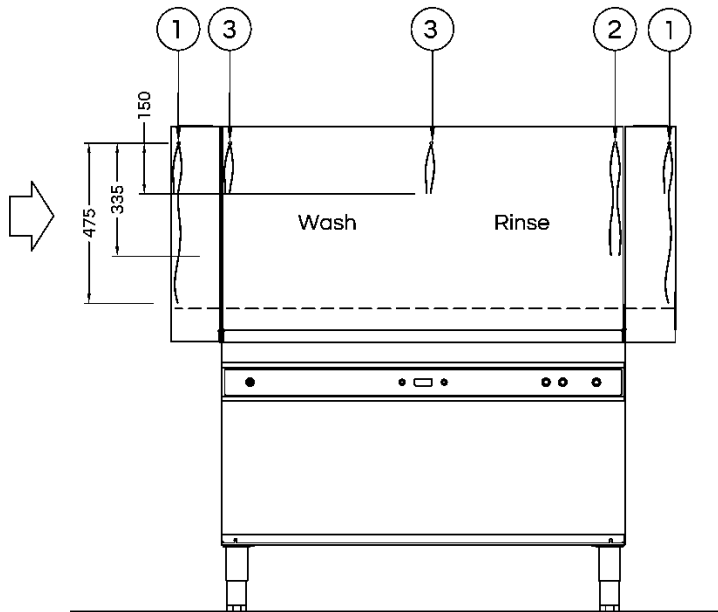

Types Of Curtains

1. Long anti splash curtain 600 x 475 (Part number: 840 90011).
2. Medium anti splash curtain 600 x 335 (Part number: 600 90071).
3. Short anti splash curtain 600 x 150 (Part number 840 90013).

The Purpose of Curtains:

- To keep the heat inside the zones of the machine.
- To stop water splashing from one zone to another. This prevents wash and rinse water mixing. If this happens the water quality will be reduced.
- Curtains must be placed in their correct positions to work properly. They must also be the correct way around.
- Broken curtains need to be replaced promptly.

Weekly Cleaning

- Remove curtains from hooks.
- Place each curtain into a dishrack and wash through the machine.

Operator Troubleshooting

Issue	Cause										
	POOR PRE-SCRAPING	CARRY OVER OF SOAP FROM SINK	OVERLOADING RACKS	POOR MACHINE CARE	JETS BLOCKED OR ARMS OBSTRUCTED	CURTAINS NOT FITTED CORRECTLY	WATER SUPPLY PRESSURE LOW	POOR WATER QUALITY**	RINSE TEMPERATURE LOW <75 ° C	PAWL DRIVE NOT OPERATING	CRASHING SOUND AGAINST DOOR
DISHES NOT CLEAN	●		●	■	■		■	■	■		
STAINING	●				●		■	■	■		
FOAMING		●		■							
PROTEIN BLOOM	■		■	●	■		■		●		
DIRTY MACHINE	●			●	■		■	■	■		
FOOD RESIDUE ON WARE	■		●	■	■		●	■	■		
FILM/SPOTS ON WARE			■	■	■		■	●	■		
DETERGENT RESIDUE					■	●	■				
GREASY FILM/NO FIZZ			■				●	■			
WET WASHWARE			●	■			■				
SCALE BUILD UP IN MACHINE				■				●			
FILTERS ON OTHER EQUIPMENT								●			
LIMIT SWITCH ACTIVATED										●	
WASH ARM NOT FITTED PROPERLY											●
MACHINE STOPS & REFILLS CONSTANTLY						●					

● Likely cause ■ Possible cause

* For issues most likely due to incorrect chemical dosages or other chemical issues, we recommend you consult your chemical supplier and/or a local chemical expert prior to calling in a dishwasher technician.

** For issues that are likely due to poor water quality (scale building up, filters being required on other kitchen equipment etc.), we recommend you consult a local water specialist prior to calling in a dishwasher technician.

IF PROBLEMS PERSIST CONTACT MOFFAT SERVICE ON 1300 264 217

Schematic Diagram

CD120 Schematic Diagram

- Part #: 260100
- Date: 18-01-2022
- Version: 1-A

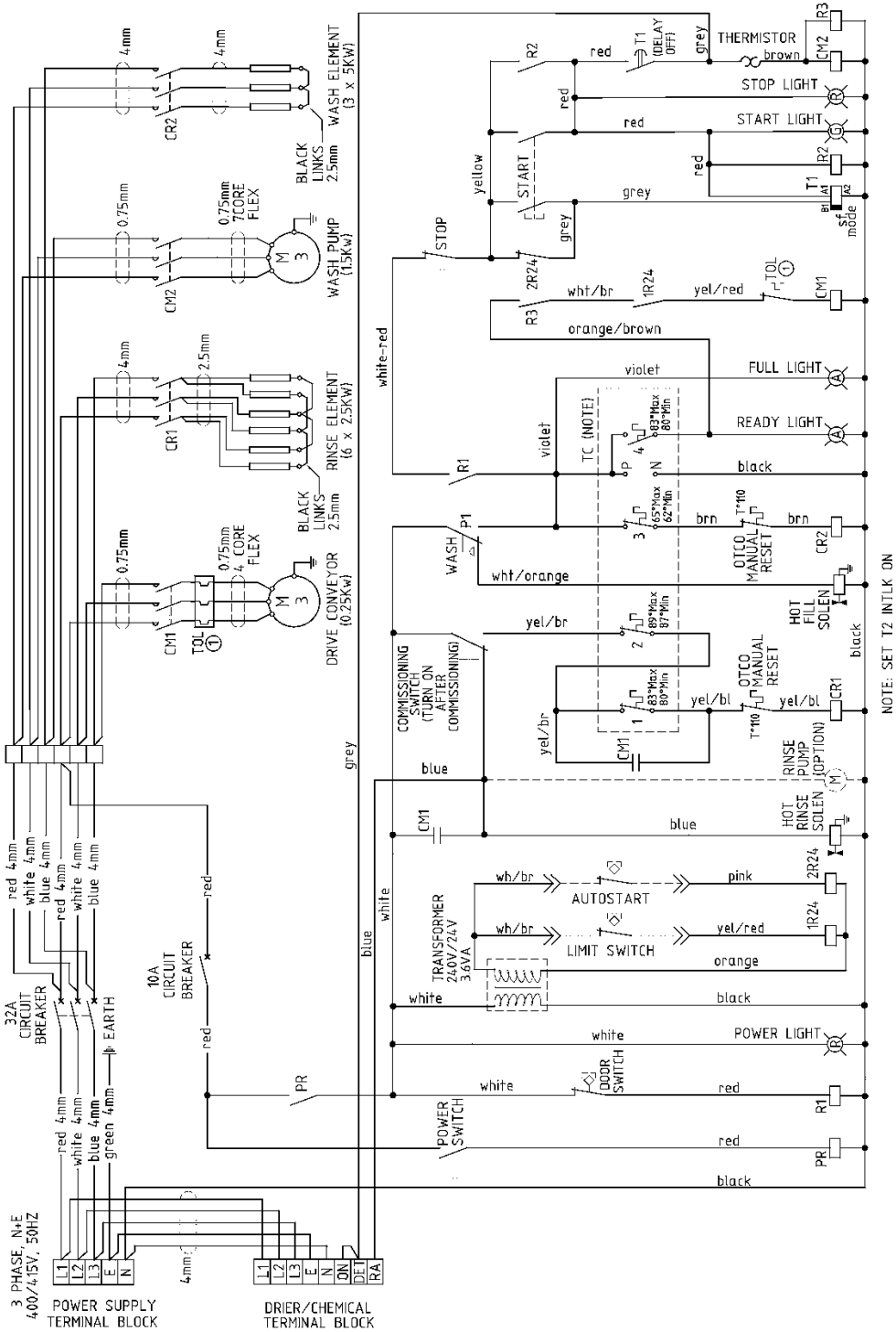

Accessories

CD100 Accessories

- Part #: CD100 ACW
- Date: 18-02-2020
- Version: 1-A

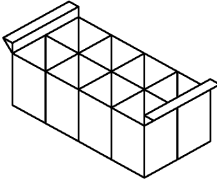

C660508
CUTLERY BASKET CP8 FOR 500mm

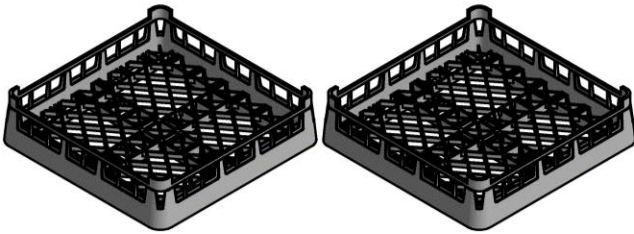

600 70029
2 x CUPRACK CB 500mm X 75mm high

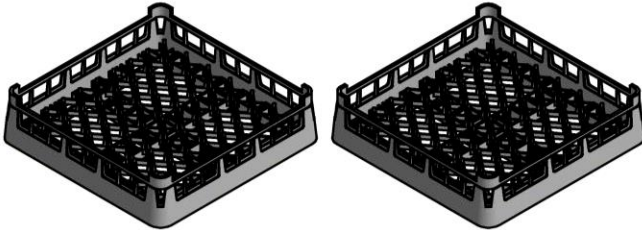

600 70028
2 x DISHRACK P12/18 500mm 18 DISH

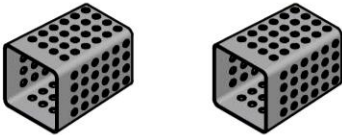

C660503
2 x CUTLERY CONTAINER G

Information supplied in this manual is copyright. No part of this work may be reproduced or copied in any form or by any means, electronic or mechanical without the express permission of the author/publisher

Distributed in Australia by Moffat Pty Limited



740 Springvale Road
Mulgrave 3170
Victoria
Australia

24HR Service 1300 264 217
Parts 1300 263 107
Tel 03 9518 3888
Fax 03 9518 3818
E-mail sales@moffat.com.au
web www.moffat.com.au

ISO9001

All Washtech products are designed and manufactured by Washtech using the internationally recognised ISO9001 quality management system, covering design, manufacture and final inspection, ensuring consistent high quality at all times.

In line with policy to continually develop and improve its products, Washtech Ltd reserves the right to change specifications and design without prior notice.

an Ali Group Company



The Spirit of Excellence