

XG

Operator Manual



WASHTECH[®]
PROFESSIONAL WASH SYSTEMS



WARNING

Before installation and commissioning, you must read the safety instructions and warnings carefully and all the warning labels attached to the equipment.



IMPORTANT

Failure to comply (even partially) with the instructions given in this manual will invalidate the product warranty and relieves the manufacturer of any responsibility



IMPORTANT

The alteration of machine operation, design or the replacement of parts not approved by the manufacturer may void warranties and approvals.



IMPORTANT

This machine is intended for commercial use only.

CONTENTS

Safety Instructions.....	3
Installation.....	4
Installation Diagram.....	5
Operating Procedures.....	6
Troubleshooting.....	8
Schematic Diagram.....	9
Wiring Diagram.....	10
Accessories.....	11

We have checked that the contents of this document correspond to the model described. There may be discrepancies nevertheless, and no guarantee can be given that they are completely identical. The information contained in this document is reviewed regularly and any necessary changes will be included in the next edition. We welcome suggestions for improvement.

Specifications and document subject to change without prior notice.

Information supplied in this manual is copyright. No part of this work may be reproduced or copied in any form or by any means, electronic or mechanical without the express permission of the author / publisher.

Service 1 800 622 216

Parts 1 800 337 963



Distributed in Australia by Moffat Pty Limited
740 Springvale Road, Mulgrave, Victoria
Tel 09 9518 3888 | Fax 03 9518 3818

Safety Instructions



WARNING

Equipment contains dangerous voltages and can be hazardous if installed or operated incorrectly. Non-compliance with warnings or failure to follow the instructions contained in this manual can result in loss of life, severe personal injury or serious damage to property.

Installation

- Use qualified, skilled personnel
- Follow installation instructions
- Connect to correct voltage and supply current
- Provide fully accessible electrical Isolation Switch & water supply valves

Training and Supervision

- Read and understand the Operating instructions and train all staff
- This appliance must not be operated by children or infirm persons
- Machine panels must only be removed by suitably qualified and trained personnel – internal hazards include live electrics and very hot surfaces
- This appliance is not intended for use as a stepladder

Hot Surfaces

- Some surfaces may be hot or very hot

Chemicals

- Commercial dishwashing detergents are hazardous – handle with care
- Read and follow the safety information found on the labels of detergent containers and Material Safety Data Sheets
- Use protective eyewear and clothing if decanting containers

Hot Water

- Do not put hands in wash water which may be over 60°C and contain hazardous caustic detergent
- Rinse water can be over 90°C
- Door safety switches are designed for emergency use only

Cleaning

- Do not hose down the machine or splash water over the exterior
- Watch for broken glass etc when cleaning the inside of the machine

Service/repair

- Under no circumstances the user should attempt to carry out repairs
- All service/repair work must be carried out by qualified personnel only

Power Cord Replacement

- If the supply cord is damaged, it must be replaced by the manufacturer or its service agent or a similar qualified person in order to avoid a hazard

Installation Checklist



WARNING

Installer must be suitably qualified and ensure compliance with all codes and standards including AS/NZS3500.1.

Unpack

- Unpack the machine, check for damage and complete delivery.

Positioning

- Place machine on sound waterproof self draining floor, fit feet and adjust feet to level
- Allow room for adjacent chemical containers

Water

- Flush supply lines before connection
- Connect hose supplied to adjacent accessible isolator valve - 20 mm 3/4 male
- Flow rate required - 20 litres per minute
- Temperature - 65°C
- Consumption per cycle - 1.5 litres
- Pressure required - 200-350 kPa - fit limiter above this pressure
- Back Flow - Atmospheric Vacuum Breaker
- Potable water quality is required - filter or soften if necessary

Water Quality Requirements

Hardness	ppm		pH			
min	20		7			
max	100		8			
Ions	Cl ⁻	SO ₄	Fe	Mn	Cu	Cl ₂
Max mg/L	100	400	0.1	0.5	0.05	0.1

Power

- Machine shipped with cordset for 15 A 240V 50Hz via adjacent switched outlet

Waste

- Connect drain pump hose supplied to upstand or sink waste connection

Detergent

- Note that detergent is hazardous - read instructions and handle with care
- Insert hose into container of commercial dishwasher low foam detergent
- Pump will prime as machine fills and then comes up to strength with use

Rinse Fluid

- Insert hose into adjacent container of commercial dishwasher rinse fluid
- Injector accessible via front panel - increase consumption by winding adjusting screw out
- Every turn of the adjusting screw will increase the dose by about 0.4ml

Operation

- Run several cycles, ensure that operator has read and understands instructions

Troubleshooting Installation

- If machine doesn't fill after switching on power, check & ensure that hot water supply tap is open, water supply pressure is not below specification

XG Installation Diagram

XG INST 24-03-17 3 C

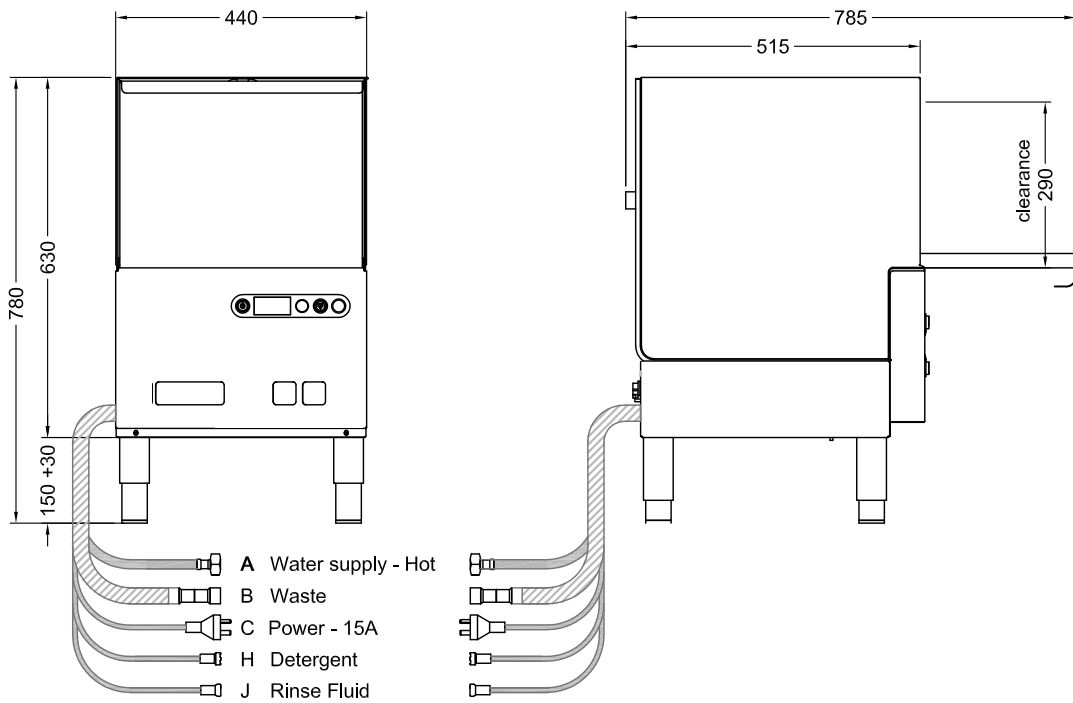

XG Machine Operation

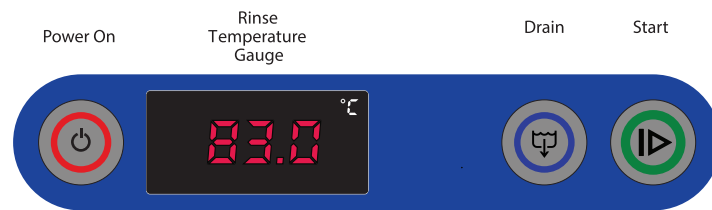

START UP

Turn machine on at wall. Fit filter, upstand and shut door.
Press Power On button on machine.
Power button light glows red and machine fills automatically
Rinse temperature will begin to rise on the temperature gauge once the machine has filled.

OPERATION

Load rack into machine and shut door
Press Start button to activate 1 minute cycle - start button glows green while machine operates.
When Start button light goes out, cycle is complete.
Remove rack, close door.

NOTE: Machine might operate longer than specified above if rinse water temperature is below required temperature.

SHUT DOWN EVERY NIGHT

Open door and press Drain button
Drain button glows blue as machine drains.
After draining starts remove drain upstand once the water level is below the top of the upstand.
Allow to drain for approximately 1 minute or until wash tank is empty.
Turn Drain and Power buttons off.
Remove filter and rinse clean.
Replace filter and drain upstand.

DAILY CLEANING

The machine must be drained and cleaned at the end of each day.
Drain the machine as per the shut down instructions.
Remove, clean and replace filters.
Regularly check the wash and rinse jets on the wash and rinse arms and clean if necessary.

MAINTENANCE

Regular servicing of the dishwasher is essential for high performance, efficient operation and long machine life.
Contact us for information on a maintenance program.

WASHTECH®

Service 1 800 622 216
Parts 1 800 337 963



Operating Procedures

PRE-RINSING

Pre-scraping of dishes is required by Food Hygiene Regulations. The best method is to pre-rinse with warm water with a Fisher Pre-rinse Unit - or alternatively by scraping or dunking in water. Cutlery should be pre-soaked in warm water, preferably containing a cutlery pre-soak compound - refer to your chemical supplier.

RACKING PROCEDURES

Do not overload racks or cutlery containers, minimise the overlap of crockery. Wash cutlery unsorted, handles down. Cycle times are short and water consumption per cycle low - so there is no advantage in overloading racks.

CYCLE TIMES

The XG has A 60 second cycle.

CHEMICAL

Correct type and quantity of detergent is essential for good results. Use good quality chemicals and regularly check containers. Discuss the use of drying agent and cutlery pre soak solution with your chemical supplier. Detergent dosing can be increased/decreased via the adjusting screw on the front cover. Rinse Aid dosing is factory set to a low injection rate and will take many cycles to prime. The operator can adjust this via the adjusting screw on the front cover.

DRYING

Single tank commercial dishwashers do not have a drying cycle. However, the machines do rinse at high temperatures which promotes fast drying particularly when drying agents are used. At the end of the cycle promptly remove the rack from the machine - leave the rack on the bench for 2 to 3 minutes before emptying.

REGULAR CLEANING – at least once a week

Remove wash and rinse arm by undoing central thumbscrew (1). Inspect all jets including top jet (2), use toothpick or paperclip and remove jets if necessary to flush and clear. Remove upstand (3) and filter (4). Clean and replace all items.

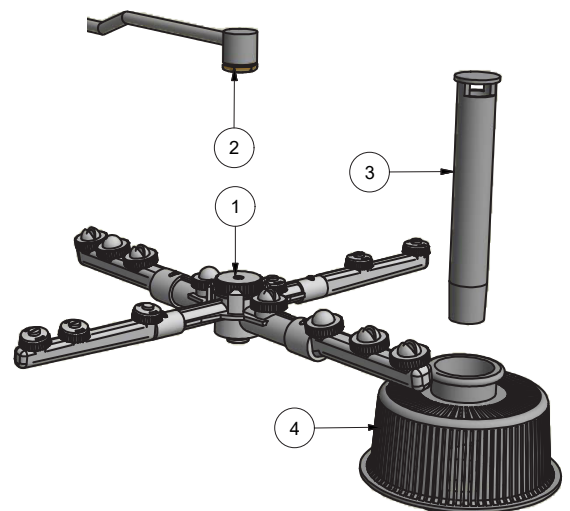

Troubleshooting

Fault	Cause	Remedy
Filling		
Not filling	Water supply valve shut	Check Water supply valve
Filling during wash cycle	Door Switch not operating	Check Door is closed
	Upstand not fitted properly	Check Drain upstand is fitted
Heating		
Dishes not hot enough	Machine not rinsing	Check water supply temperature
	Rinsing but not hot	Check water supply temperature & arms spinning freely
Cycle start		
Does not start	Door switch	Check door is closed
Cycle Finish		
Wash too long	Water supply cold	Check water supply temperature
Performance		
Poor wash result	Detergent not used	Use quality low foam product
	Overloading racks	Do not overload racks
	Not pre-rinsing	Use Fisher pre-rinse
	Wash arms not rotating	Remove and clean arms/check bushes
	Wash jets blocked	Remove arms and clean jets
	Excessive soiling	Pre-rinse/use long cycle
Poor rinse results	Unrealistic expectation	E.g. baked on soiling requires pre-soaking
	Rinse jets blocked	Remove arms and clean jets
	Rinse arms not turning	Remove arms, clean jets, check bushes
	Poor racking procedures	Do not overload racks
Not drying	Excessive wash tank soil build up	Pre-rinse, change wash water regularly
	Poor wash/rinse performance	Refer above
	Low temperatures	Check heating systems
Foaming Wash	Drying agent not used	Use quality drying agent/rinse fluid
	Excessive Rinse Fluid	Adjust Rinse Fluid Injector

XG-3 Schematic Diagram

060183 30/10/18 1 C

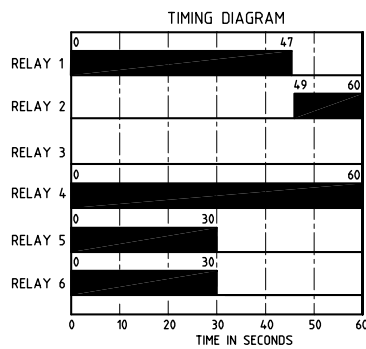
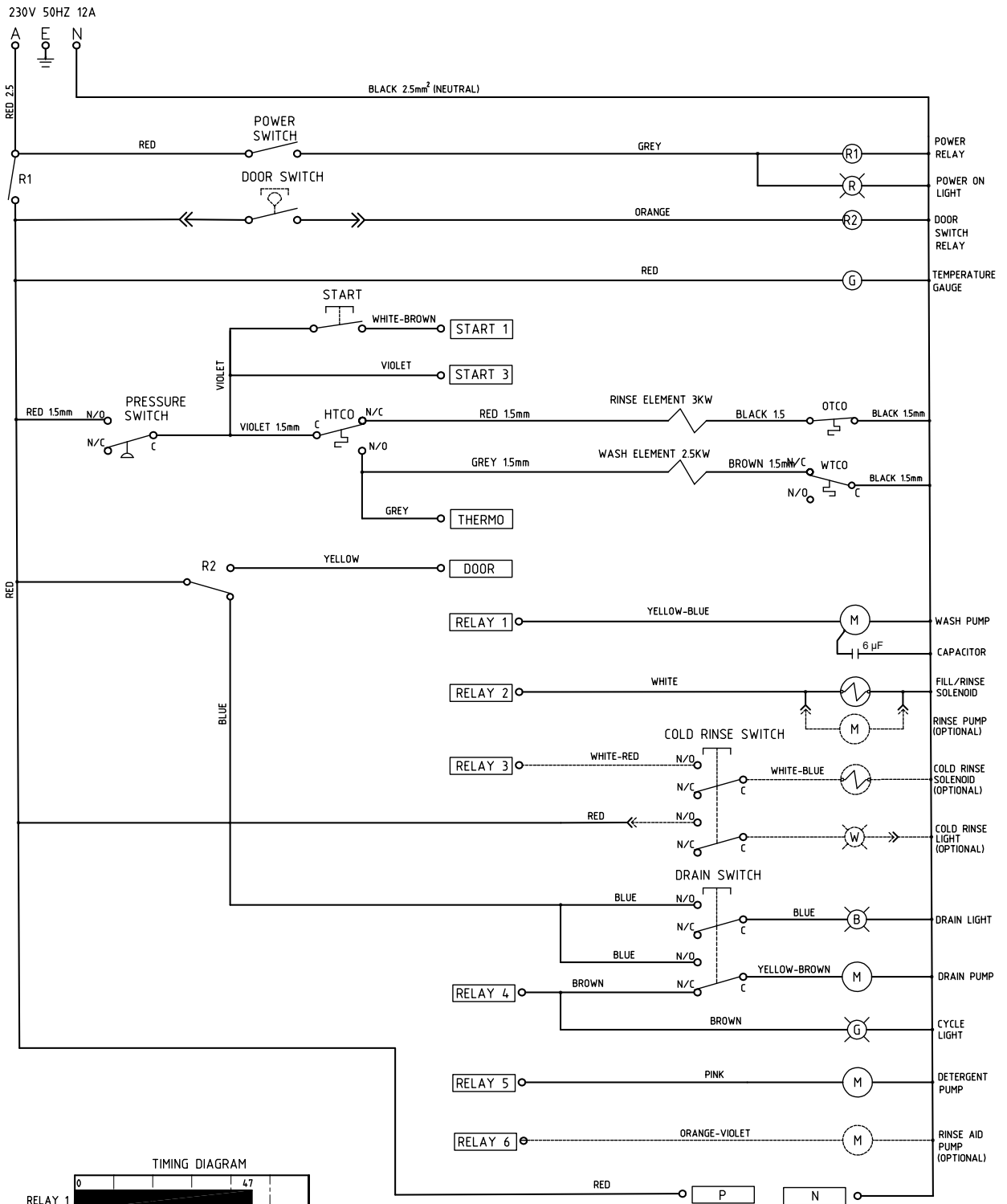

Accessories

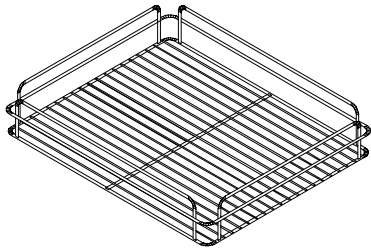

K0401
GLASS RACK 365mm

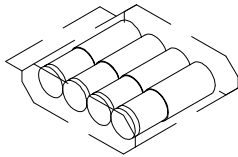

600 90021
ASSY GA/GM LEG (INOX 32x180xM10)

7026@
BAG MINIGRIP 230 x 305 x 70mu

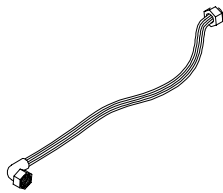

600 60080
2m HOSE ANGLE END

Notes

Information supplied in this manual is copyright.
No part of this work may be reproduced or copied
in any form or by any means, electronic or
mechanical without the express permission of the
author/publisher

Distributed in Australia by Moffat Pty Limited



740 Springvale Road
Mulgrave 3170
Victoria
Australia

24HR Service 1 800 622 216
Parts 1 800 337 963

Tel 03 9518 3888
Fax 03 9518 3818
E-mail sales@moffat.com.au
web www.moffat.com.au

ISO9001

All Washtech products are designed and
manufactured by Washtech using the
internationally recognised ISO9001 quality
management system, covering design,
manufacture and final inspection, ensuring
consistent high quality at all times.

In line with policy to continually develop and
improve its products, Washtech Ltd reserves the
right to change specifications and design without
prior notice.

an Ali Group Company



The Spirit of Excellence