

SIDE VIEW	Model	A530v	A540v	A550v
	Dimensions (cm)	90*54*79	120*54*79	150*54*79
	Capacity (Litres)	140L	190L	240L
	Shelves	2	2	2
	Watts	475W	623W	659W
	Net Weight (Kgs)	90KGS	105KGS	120KGS
	Gross Weight (Kgs)	100KGS	115KGS	130KGS
	Packing Size(cm)	L98*W58*H93	L128*W58*H93	L158*W58*H93
	Q' ty/20' container	48	34	26
	Q' ty/40' container	96	72	58

### Electric Wiring Diagram

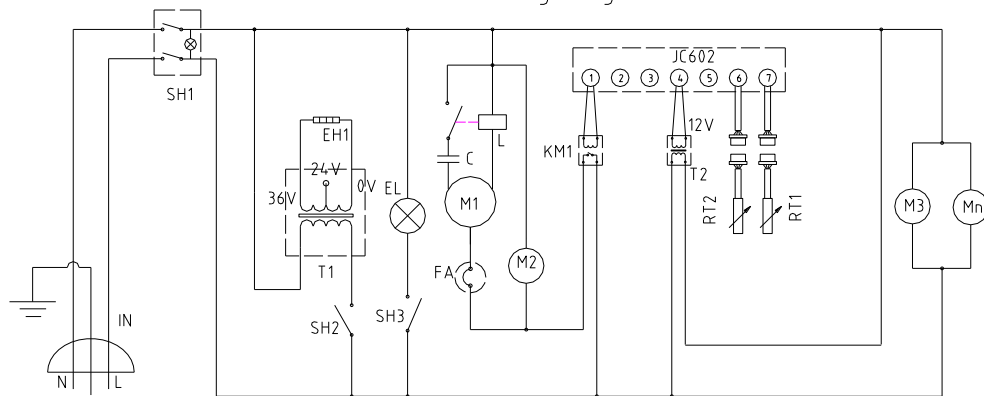

230V/50Hz / AC  
(110V/60Hz / AC)

- |                    |                            |                                |
|--------------------|----------------------------|--------------------------------|
| SH1 POWER SWITCH   | M1 COMPRESSOR              | RT1 SENSOR FOR DEFROSTING      |
| SH2 HEATING SWITCH | FA OVERLOAD PROTECTOR      | RT2 SENSOR OF CABINET TEMP.    |
| SH3 LIGHT SWITCH   | M2 CONDENSER MOTOR FAN     | T1 TRANSFORMER OF HEATING WIRE |
| EH1 HEATING WIRE   | JC602 THERMOSTAT           | T2 TRANSFORMER OF THERMOSTAT   |
| EL LIGHT           | M3-Mn EVAPORATOR MOTOR FAN | KM1 RELAY                      |

Part number	BOM number			Description
	A530V	A540V	A550V	
1	1220170007	1220170008	1220170009	Sliding door
2	2120030019	2120030020	2120030021	Back panel
3	1103050036			Controller board
4	1205010011			Controller JC602
5	1205020002			Switch SC767
6	1205020003			Switch SC791
7	2120070022	2120070023	2120070024	Shelf
8	1220140008			right glass
9	2220030013	2220030014	2220030015	Bracket
10	1206010003	1206010004	1206010005	Light
11	2120620001	2120620002	2120620003	Light cover
12	2120070016	2120070017	2120070018	Bottom shelf board
13	8120200004			Decoration right panel
14	2120320001	2120320002	2120320003	Rear air grill
15	1204030002			Evaporator fan motor
16	2120130007	2120130008	2120130009	Evaporator rack
17	1220020002	1220020003	1220020004	Evaporator
18	1220150016	1220150017	1220150018	Curved glass
19	2220510001	2220510002	2220510003	Bar
20	1220140007			left glass
21	8120390004	8120390005	8120390006	Decoration front panel
22	8120200003			Decoration left panel
23	1220030003			Condenser
24	1204030005			Condenser fan motor
25	1204010012	1204010013	1204010013	Compressor