

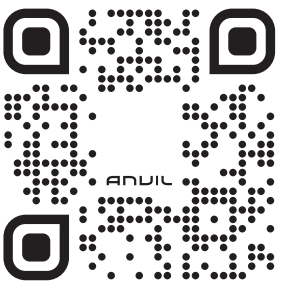

ANVIL

**Installation,
Operation and
Care Manual**



**SCAN ME
TO GO TO
WARRANTY
REGISTRATION**



4-INS-COA1005

THE CHEFS COMPANION

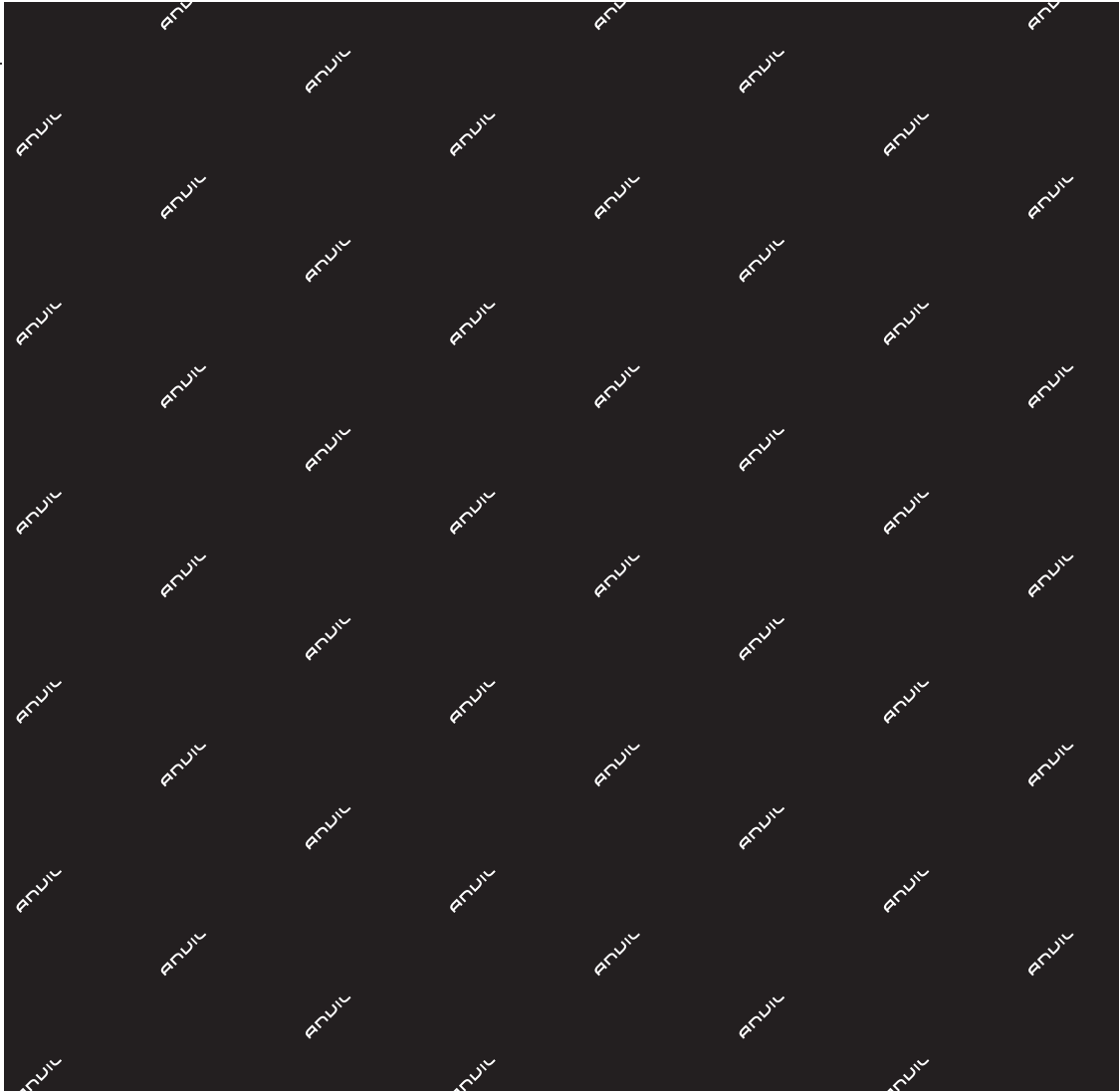

THE CHEFS COMPANION

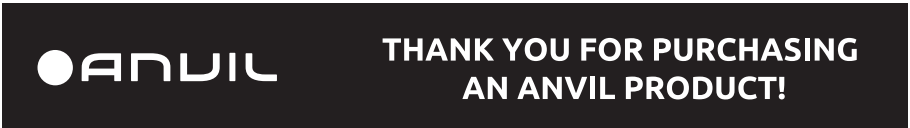

THANK YOU FOR PURCHASING AN ANVIL PRODUCT!



REGISTER ONLINE TODAY

Register your warranty on-line at www.anvilworld.com today and learn how to get the best out of your Anvil product, tips to care for your Anvil product for long lasting performance, exciting recipes and more.

NO WEB ACCESS?

If you do not have access to the Web, register by completing this form and faxing it to the Anvil head office in South Africa. Fax: +27 11 474 1630

ONLY COMPLETE IF YOU DO NOT HAVE WEB ACCESS

Company _____

Name _____

Surname _____

Telephone _____

Cellphone _____

Email Address _____

Country _____

Postal address _____

Anvil products purchased _____

Code (see box label) _____

Serial number (see back of machine) _____

INTENDED USE

- Full-Service restaurant
- Coffee Shop / Deli
- Fast Food Outlet
- Hotel
- Bed & Breakfast
- School Cafeteria

- Institutional Cafeteria
- Corporate Catering
- Private Use
- Franchisor
- Convenience Store
- Other

 ALL ANVIL EQUIPMENT COMES WITH A TWO YEAR WARRANTY ON COMPONENTS AND DEFECTIVE WORKMANSHIP.

www.anvilworld.com

LIMITED WARRANTY

All equipment which is sold under ANVIL trademark and used for commercial purposes is warranted against defects in materials and workmanship. The warranty runs for two years from the date of original installation and is for the benefit of the original purchaser only. All other Warranties, expressed or implied, statutory or otherwise, including without limitations any implied Warranty of Merchantability or fitness for purpose are excluded. The Seller shall in no event be liable for direct, indirect or consequential damages in connection with ANVIL commercial products.

The Sellers obligation under this Warranty is limited to the repair of defects without charge. Defective units must be taken or shipped, transportation charges prepaid, to ANVIL.

This Warranty is not effective if damage occurs because of accident, carelessness, improper installation, lack of proper set-up, supervision when required or if the equipment is installed or operated in any manner contrary to the installation and operating instructions. In these cases, repairs will be made at a reasonable cost. Work performed by unauthorized personnel or unauthorized service agencies using non Anvil spares voids this Warranty.



NB:

REGISTER ON-LINE TODAY

Register your warranty on-line now at www.anvilworld.com

NO WEB ACCESS

If you do not have access to the Web. Kindly register by completing the warranty registration form and fax it to the ANVIL office in the country of purchase.

Failure to do so will invalidate your warranty.

COA1005 CONVECTION OVENS

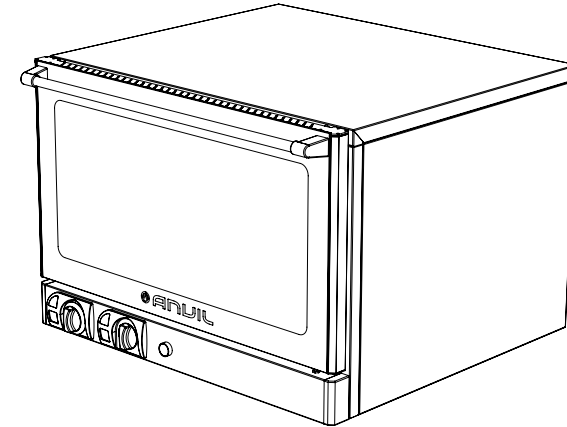

**INSTALLATION OPERATION AND CARE OF
COUNTER-TOP CONVECTION OVEN
MODEL: COA1005 R04/COA1005-ICE**

UNPACKING

Unpack the product and check for any damage incurred during transit. This should be reported to the responsible carrier, railway or postal authority, and a request for a damage report should be made.



THESE INSTRUCTIONS MUST BE FOLLOWED FOR US TO GUARANTEE OUR FULL SUPPORT OF YOUR CLAIM FOR PROTECTING AGAINST LOSS FROM CONCEALED DAMAGE. THE FORM FOR FILING SUCH A CLAIM WILL BE PROVIDED BY THE CARRIER.

GENERAL INSTALLATION AND OPERATION INSTRUCTIONS

These Countertop convection ovens have been designed for the following uses

- Baking of fresh or frozen bakery and pastry products
 - Cooking of gastronomy products, either fresh or frozen
 - Regeneration of fresh or frozen food
1. Protective Film - Carefully remove the protective film from the stainless steel before using oven for the first time. If any glue residue should remain, remove it with a suitable solvent recommended for stainless steel. It is important to remove this film before installation and use other wise it will stick onto the stainless steel and become very difficult to remove thereafter.
 2. Positioning - Install the counter top oven in the most convenient location for ease of cleaning, maintenance and general operation. The unit should be placed a minimum distance of 100mm from any adjacent wall. If this appliance is to be positioned in close proximity to a wall, partitions, kitchen furniture, decorative finishes, etc. It is recommended that they be made of non – combustible materials. If not, they shall be clad with a suitable non – combustible heat insulating material, and the closest attention be paid to the fire prevention regulations. It is important to observe the recommended space at the back of the oven due to the exhaust air vent duct being positioned at the rear of the unit. Hot exhaust gas can create a fire hazard.

3. Earthing - These countertop convection ovens require a grounded, receptacle.
4. Fit the shelves and shelf runners in the desired position inside the unit. TO ALLOW PROPER OPERATION, ALLOW A SPACE OF AT LEAST 40mm BETWEEN EACH TRAY IN ORDER FOR THE HOT AIR TO CIRCULATE CORRECTLY. For baking delicate products please use the baffle plate included. This plate is fitted to the fan plate inlet. If higher airflow is required the baffle plate is not required.
5. The COA1005 oven requires either a 2 phase connection or a dedicated single phase connection to the distribution board. Please consult a qualified electrician. The COA1005-ICE requires a single phase 240V AC 50 Hz connection.

WATER CONNECTION

1. This oven is supplied with a water spray steam function. A water connection may be fitted directly to the unit using $\frac{3}{4}$ " fittings. The water pressure should be between 0.5-2 bar. Any supply pressure above this requires the fitment of an inline pressure reducing valve.

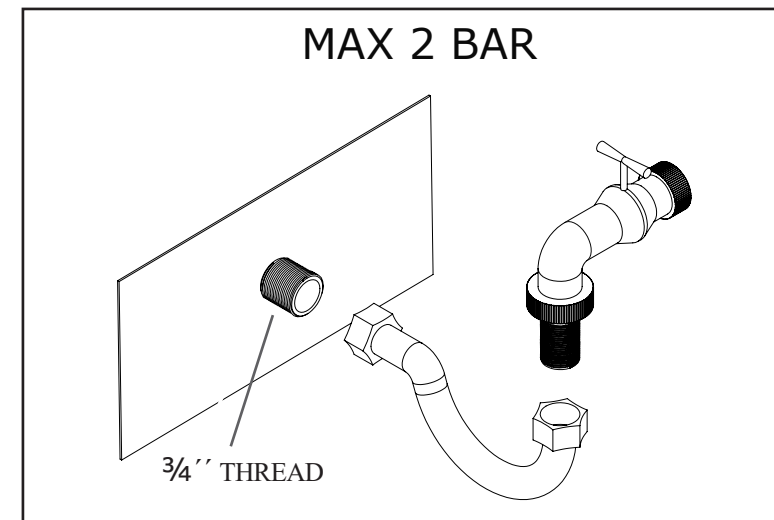

BAFFLE PLATE

1. The optional fan baffle plates act as restrictors when reduced airflow is required. This could apply when baking muffins or delicate pastries.
2. The baffle plate hooks on to the fan cover, located inside the oven see (figure 2).

figure 2

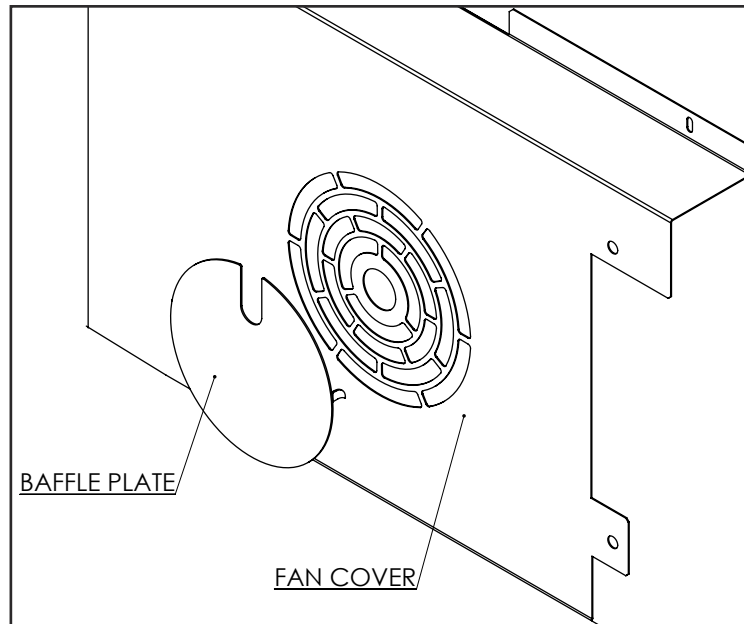

PARTS LEGEND GRANDE FORNI CONVECTION OVEN MODEL: COA1005 R05/COA1005-ICE

Part No.	SCE Part No.	Description
1	5-2800W-CAT-PRO	ELEMENT
2	82-C05-SS-FCASS	FAN COVER PLATE
3	10-GRD-COA1005	FAN GRID - COA1005- 150 x 150 SS
4	10-SR-COA1005	SHELF RUNNER
5	6-OVEN-SHE-TS-1	SHELF RUNNER THUMB SCREW
6	10-SHE-COA105-1	PROTON SHELF
7	1-PL-BMA0001	PILOT LIGHT
8	3-CPF-AXIS	CONTROL PANEL PLASTIC
9	3-CPB-FTA0400	CONTROL KNOB PLASTIC
10	82-C05-SS-HAND	OVEN HANDLE
11	3-DH-COA1001	PLASTIC HANDLE NODE
12	7-OH-COA1005B	DOOR HINGE
13	3-DS-COA2005	DOOR SEAL
14	10-GLAS-COA805-I	INNER GLASS LOW E
15	82-C05-SS-DOFRM	OUTER DOOR FRAME
16	4-DL-L-APEX	ANVIL APEX DOME LABEL
17	4-BADGE-BEZEL	BADGE BEZEL
18	1-2HR-TIMER	2HOUR TIMER
19	1-PBG-JES0002	PUSH BUTTON
20	1-EGO-150	THERMOSTAT
21	1-SEL-SWITCH	SELECTOR SWITCH
22	3-ECAPS-COA2003	END CAP PLASTIC
23	3-L-RDS	LARGE RUBBER FEET
24	82-C05-MS-BTPAN	BOTTOM COVER PANEL
25	82-C05-SS-CNTRLPAN	CONTROL PANEL ASSEMBLY
26	3-CB-3PHASE	2 PHASE CONNECTOR BLOCK
27	1-SV-2WAY	2 WAY SOLENOID VALVE
28	3-GH-FFA3010	8MM GAS HOSE
29	7-HC-12MM	12MM HOSE CLAMP
30	8-PROTON-WI	WATER INJECTOR
31	1-TIMER-COA1005	FAN MOTOR REVERSE TIMER
32	1-CAP-COA1005	FAN MOTOR CAPACITOR 5MF/450V
33	1-220V-CONT-32A	CONTACTOR
34	1-FAN-COA1005	FAN MOTOR WTH IMPELLER
35	82-C05-MS-BCPAN	REAR COVER
36	82-C05-SS-EXBKT	CHIMNEY ASSEMBLY
37	82-C05-SS-INTER	INNER CHAMBER
38	82-C05-SS-OTCAS	OUTER ENCLOSURE
39	1-LB-COA1001	OVEN LIGHT BULB
40	1-OVEN-LH	OVEN LIGHT BULB HOLDER
42	1-LS-COA1005	LIMIT SWITCH
43	1-THERM-SAF-TSA7009	SAFETY THERMOSTAT

**EXPLODED DIAGRAM
GRANDE FORNI CONVECTION OVEN
MODEL: COA1005 R05/COA1005-ICE**

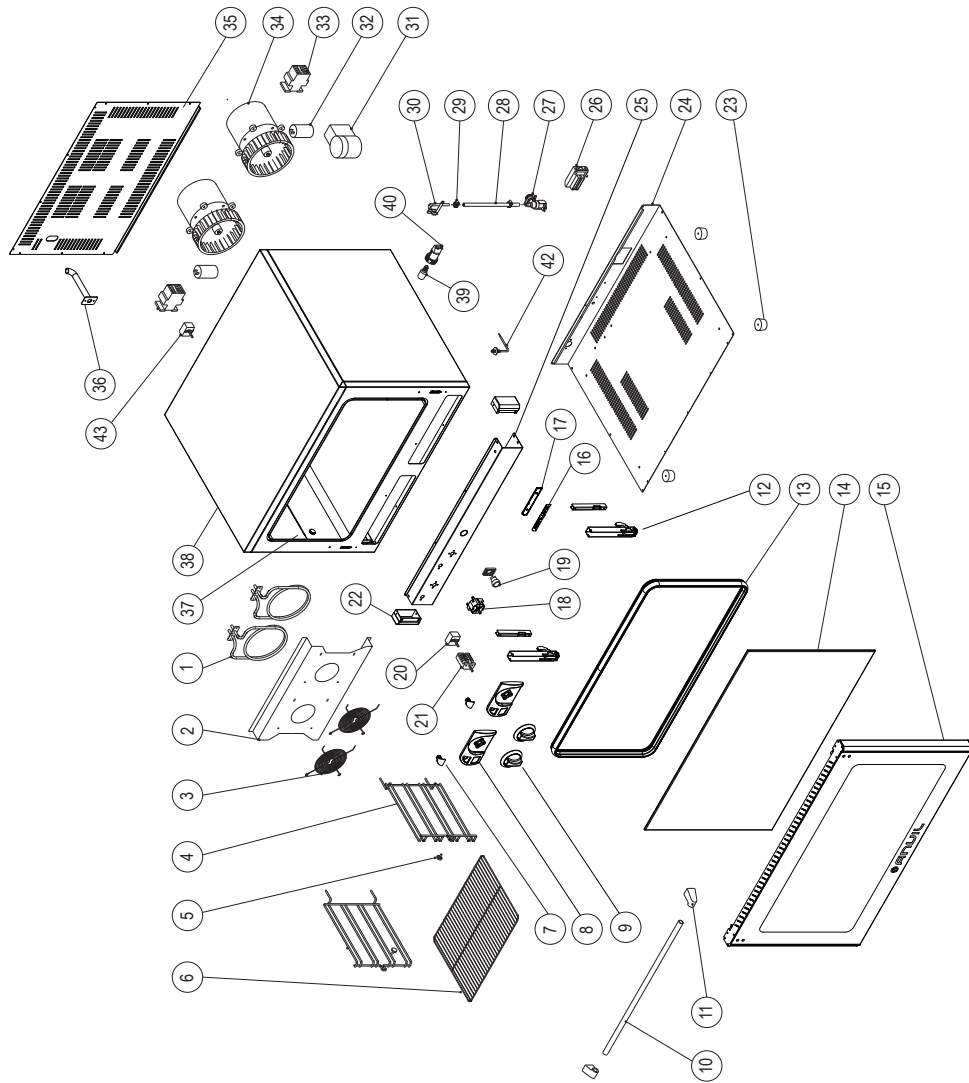

OPERATION (COA1005)

1. Set the BAKE CONTROL to the desired temperature. Set the TIMER CONTROL to the desired time or bypass the timer to the 'ON' position as marked on timer control knob. The fans and the oven light will operate continuously, however the elements will switch off at the end of the timed cycle. The pilot light will indicate when the heating elements are energised. The desired temperature is reached when the pilot light starts to switch on and off. The oven is fitted with reversing fan motors which operate independently on a 4 minute timed cycle.
2. The unit has a green push button that activates a spray of water, which creates humidity inside the oven chamber. This feature is used when a crisp outer layer is required on such products such as bread rolls. Humidity should only be injected in 2-second pulses after the oven has reached operating temperature and the product has just been placed inside i.e. at the beginning of the baking cycle.
3. Additionally the COA1005 only is provided with a proximity switch which switches off the fan and heaters when the door is opened thus ensuring that the hot air in the oven cavity is not lost through the opening of the door. Once the door is closed the fan reversing timer and elements are re-energised.



WARNING

Electric Shock Hazard.

Keep water and other liquids from entering the inside of the equipment. Liquid inside the equipment could cause an electrical shock

Do not spray water or cleaning products. Liquid could contact the electrical components and cause a short circuit or an electrical shock. Do not use equipment if power cord is damaged or has been modified

SAFETY

READ ALL INSTRUCTIONS BEFORE USE. FAILURE TO FOLLOW THESE PRECAUTIONS COULD RESULT IN INJURY TO YOURSELF AND OTHERS

1. When this appliances is to be positioned in close proximity to a wall, partitions, kitchen furniture, decorative finishes, etc. it is recommended that they be made of non-combustible material. If not, they shall be clad with a suitable non-combustible heat insulating material, and the closest attention be paid to fire prevention regulations.
2. Use the appliances on an individual 15A mains outlet only.
DO NOT OVERLOAD THE CIRCUIT.
3. Ensure that the equipment and the power supply cord does not come into contact with hot surfaces.
4. Supervision is necessary when the appliance is used in close proximity to children.
5. If the supply cord is damaged, it must be replaced with a new cord assembly available from the suppliers agent.
6. Use only earthed outlets matching the serial plate voltage.
7. Have equipment installed by a qualified personnel in accordance with local codes and ordinances.
8. Use equipment in a flat level position.
9. Do not operate unattended
10. The equipment may be hot, even though the pilot light is not on.
11. Do not operate if equipment has been damaged or is malfunctioning in any way.
12. These appliances are designed to run only on alternating current (A.C.) **DO NOT CONNECT TO DIRECT CURRENT (D.C)**

POSITIONING DIAGRAM GRAND FORNI CONVECTION OVEN MODEL: COA1005 R05

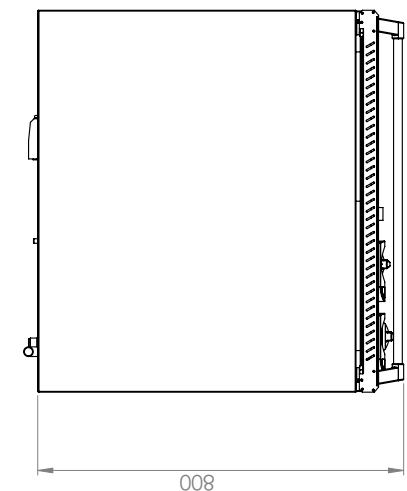
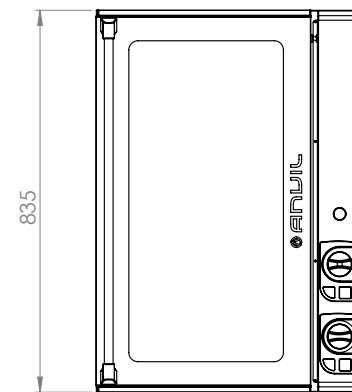
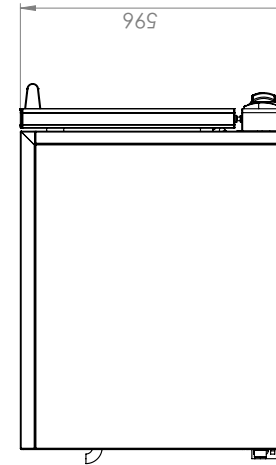

WIRING DIAGRAM LEGEND
GRAND FORNI CONVECTION OVEN
MODEL CODE: COA1005 - ICE

LEGEND	DESCRIPTION	PART NUMBER
S	STAGE SWITCH	1-SEL-SWITCH
L	INTERIOR LIGHT	1-OVEN-LH
M1/M2	PROTON OVEN FAN	1-MOT-COA1005
B1	CONTROL THERMOSTAT	1-EGO-150
H2	BAKE PILOT LIGHT	1-PL-GP
E1/E2	BAKE ELEMENT 1500W /230V	5-1500W-COA1005
L1/L2	INTERIOR LIGHT	1-OVEN-LH
H2	BAKING PILOT LIGHT	1-PL-GP
C1	MINI CONTACTOR 220V COIL	1-220V-CONT-40A
B2	OVER TEMPERATURE THERMOSTAT	1-THERM-SAF-TSA7009
P1	PUSH BUTTON SWITCH	1-PBG-JES0002
MR	MOTOR REVERSE TIMER	1-TIMER-COA1005
CAP1/CAP2	MOTOR CAPACITOR	1-CAP-COA1005
S1	SOLENOID VALVE	1-SV-2WAY
DS	DOOR SWITCH	1-LS-COA1005
T	TIMER 2 HOUR	1-2HR-TIMER

13. Extreme caution should be exercised when using containers other than the intended proper heat tempered metal and glass pans for baking.
14. Do not cover any part of the oven or a sheet pan used as a drip tray with aluminium foil as this may cause overheating of the oven.

COOKING TIPS

Cooking is not an exact science. Due to many variables such as size and quantity of food, temperature of food, etc. However, the following tips may prove to be helpful

1. ALWAYS PREHEAT OVEN FOR A MINIMUM OF 10 MINUTES.
2. Shelf positions – When cooking larger volume foods, it may not be appropriate to use all the shelves. Use the shelf positions that best centre the food in the oven. You may use a sheet pan as a drip tray on the bottom of the oven.
3. Warming – Set temperatures around 80°C/176°F.
4. Re-heating – If food is frozen, cook longer at lower temperatures. This will ensure that food is heated evenly and prevent food fillings from being served too hot. For proper food safety, be sure that internal temperature of reheated food reaches at least 73°C / 165°F. For best results it is recommended that the food be defrosted prior to re-heating.
5. For even cooking – Always space food evenly on your cooking pans, space pans evenly in the oven, and leave space between shelves for proper air circulation.
6. When preparing meat – Always put a sheet pan on the bottom of the oven cavity to catch any spillage.
7. DO NOT cover any part of the oven or a sheet pan used as drip tray with aluminium foil. This can cause the oven to overheat and loose foil may get caught in the fans.



TIP : COOKING AT A HIGHER TEMPERATURE WILL NOT REDUCE YOUR COOKING TIME ! IT WILL PRODUCE UNSATISFACTORY BAKING AND ROASTING RESULTS.



WARNING

Burn Hazard.

Do not touch hot food, liquid or heating surfaces while equipment is heating or operating

Hot surfaces and food can burn skin. Allow the hot surfaces to cool before handling

CLEANING AND MAINTENANCE INSTRUCTIONS

1. Always ensure that the unit is disconnected from the main power supply before cleaning.
2. The unit should not be cleaned with a water jet or immersed in water. Use only a damp cloth or sponge dipped in soapy water.
3. Always clean equipment thoroughly before first use. However, do not use chlorine or chloride – based products to clean the unit. These may lead to corrosion and pitting and will result in voiding the warranty on the unit.
4. Wipe off the unit with a dry cloth and wait at least half an hour before re – connecting to the main power outlet.
5. The unit is fitted with Low “E” glass which reflects heat inward making heat retention more efficient. Scouring with abrasive cleaners will damage coating and invalidate warranty.
6. Take care when removing the inner glass panel as the hinge tension will slam the door closed if not held.
7. Take care to replace the inner glass panel so that the Low “E” surface is facing the interior of the oven.



THIS APPLIANCE SHOULD NOT BE CLEANED WITH A WATER JET OR IMMERSSED IN WATER. USE ONLY A DAMP CLOTH OR SPONGE DIPPED IN SOAPY WATER. DO NOT USE STEEL-WOOL WHICH WILL MARK THE BRIGHT STAINLESS STEEL FINISH

WIRING DIAGRAM GRAND FORNI CONVECTION OVEN MODEL CODE: COA1005 - ICE

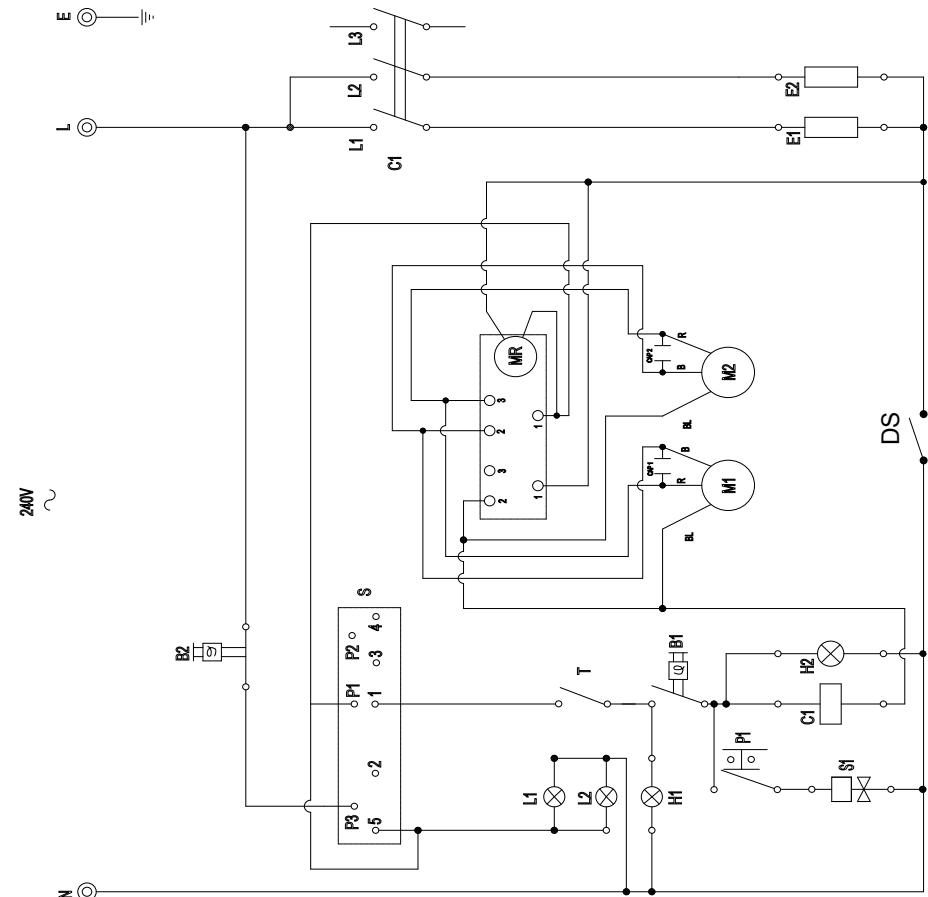

WIRING DIAGRAM LEGEND
GRAND FORNI CONVECTION OVEN
MODEL CODE: COA1005 R03

LEGEND	DESCRIPTION	PART NUMBER
S	SOLANIOD SWITCH	1-SEL-SWITCH
L	INTERIOR LIGHT	1-OVEN-LH
M1/M2	PROTON OVEN FAN	1-MOT-COA1005
B1	CONTROL THERMOSTAT	1-EGO-150
H2	BAKE PILOT LIGHT	1-PL-GP
E1/E2	BAKE ELEMENT 2800W /230V	5-2800W-CAT -PRO
L1/L2	INTERIOR LIGHT	1-OVEN-LH
H2	BAKING PILOT LIGHT	1-PL-GP
C1	MINI CONTACTOR 220V COIL	1-220V-CONT-40A
B2	OVER TEMPERATURE THERMOSTAT	1-THERM-SAF-TSA7009
P1	PUSH BUTTON SWITCH	1-PBG-JES0002
MR	MOTOR REVERSE TIMER	1-TIMER-COA1005
CAP1/CAP2	MOTOR CAPACITOR	1-CAP-COA1005
DS	DOOR SWITCH	1-LS-COA1005
T	TIMER 2 HOUR	1-2HR-TIMER

The doors can be removed for cleaning.
(Assembly instructions)

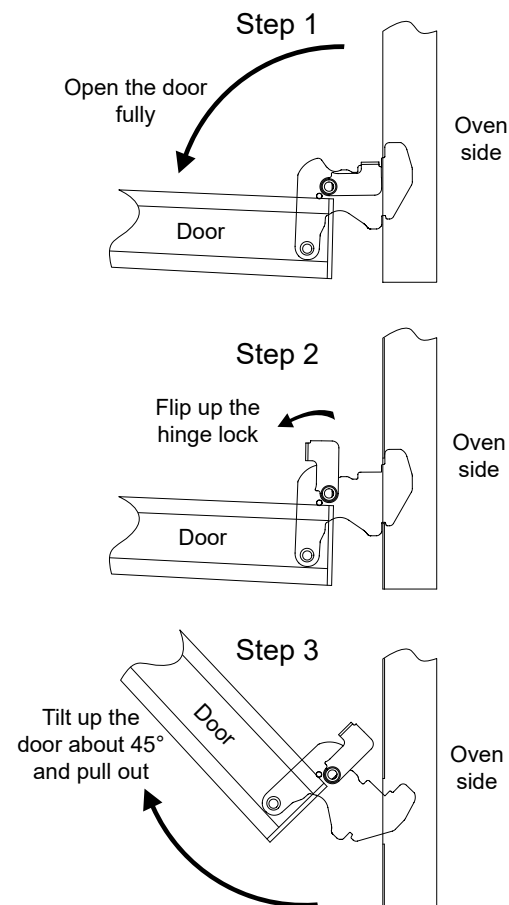

MAINTENANCE

Replacement of the internal lamp

1. Disconnect the appliance from the power supply and let it cool down if hot.
2. Remove the shelf support grid.
3. Unscrew the glass cover and replace the lamp with the correct specification – 230V/ 25 W.
4. Reassemble in the reverse order.

SPECIFIC ELECTRICAL CONNECTION INFORMATION
COA1005 - GRANDE FORNI OVEN

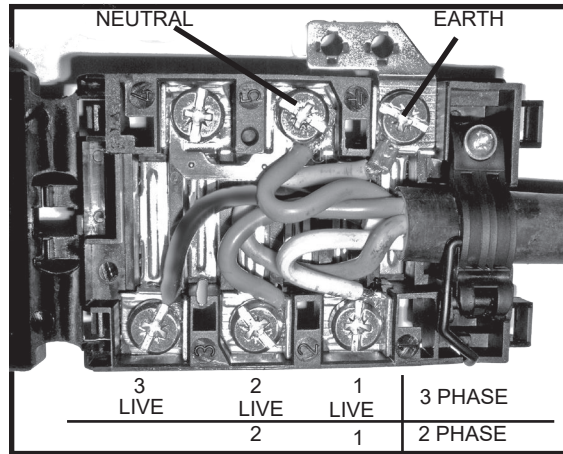

ELECTRICAL CONNECTION INFORMATION

MODEL	DESCRIPTION	VOLTS (V / Hz)	POWER (W)
COA1005	GRANDE FORNI OVEN	230 / 2P 50	5600
COA1005-ICE	GRANDE FORNI OVEN	240 / 50	3000
COA1205 / COA1203	GRANDE FORNI DIGITAL OVEN	230/ 2P 50	5600

WIRING DIAGRAM
GRAND FORNI CONVECTION OVEN
MODEL CODE: COA1005 R03

