



## Chicken Griller 8 Bird

*“Anvil’s Rotisserie produces 8 delicious chickens at a time. This unit is perfect for small supermarkets selling rotisserie style grilled chickens.”*



 ANVIL

**APEX**

### Model: CGA0008

#### APPLICATION

- Ideal for use in restaurants, take aways, canteens, small supermarkets etc.

#### CONSTRUCTION

- Full Stainless Steel construction with Chrome plated wire baskets and full removable drip tray for ease of cleaning
- A timer is fitted for controlled operation. A bypass function is provided on the timer for continuous use
- Glass front and rear makes this a good point of sale unit as the customer can see the product at all times
- Internal light to enhance the view of the chickens at all times

#### HEATING

- Thermostatically controlled
- Unique heating system ensures uniform temperature distribution



ALL ANVIL EQUIPMENT COMES WITH A ONE  
YEAR WARRANTY ON COMPONENTS AND  
DEFECTIVE WORKMANSHIP.  
[www.anvilworld.com](http://www.anvilworld.com)

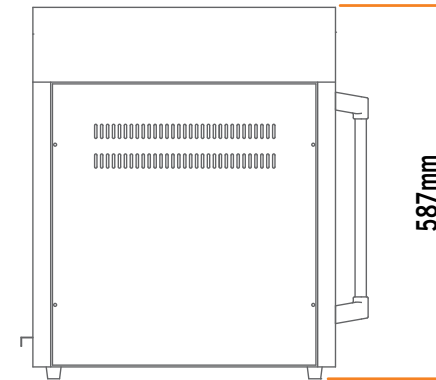
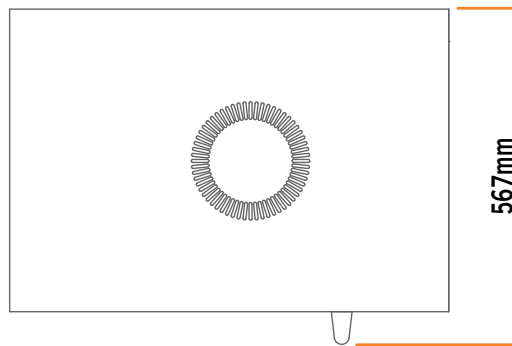
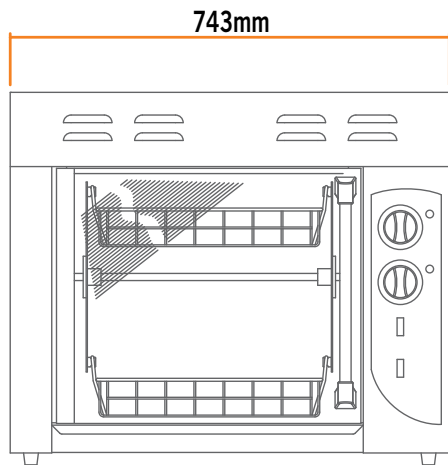

## DESCRIPTION

MODEL  
 POWER RATING(230V/50Hz)  
 DIMENSIONS (mm) (W x D x H)  
 BOX DIMNS (mm) (W x D x H)  
 PACKED WEIGHT (kg)

- Unit not available in 120V/60Hz configuration

## 8 BIRD CHICKEN GRILLER

CGA0008  
 3kW  
 743 x 567 x 587  
 832 x 602 x 722  
 38

# Model: CGA0008

NOTE: When viewing the appliance from the front in it's usual operating position, the width (W) of the product is the total distance from left to right; the depth (D) of the product is the total distance from the front to the back; the height (H) is the total distance from the bottom of the product to the top.

 ANVIL

# APEX

Note: Output performance figures quoted are dependant on various factors

Anvil reserves the right, without notice, to make changes and revisions to product specifications, materials and design, which in our opinion, will provide better performance, durability and efficiency.