

Technical data sheet for

E32D4 ON THE SK32 STAND

Full Size Digital / Electric Convection Oven
on a Stainless Steel Stand



E32D4

Unit shall be a Moffat electrically heated Turbofan convection oven. The oven shall have a one piece vitreous enamel oven chamber, stainless top and sides and safe touch vented easy clean side hinged door that offers field reversible hinging. Oven shall have capacity for four full size sheet pans. The oven shall be controlled by an electronic control having separate digital displays and adjusting knobs for time and temperature functions. The oven control shall allow both manual and programmed operating modes with programmable moisture injection, 2 speed oven fan, and 3 stage cooking. A core temperature probe M236060 is optional. The unit shall include dual halogen oven lamps. Oven shall be able to be bench mounted on 76mm feet or mounted on oven stand model SK32. Unit shall be supplied in 100% recyclable shipping packaging. This unit shall be Energy Star certified.

SK32

Unit shall be a Moffat Turbofan stainless steel oven stand. The stand shall be constructed from stainless steel tube with castors, with front castors having dual swivel and wheel locks. It shall be fitted with 6 tray runners suitable for up to 12 half size sheet pans or 6 full size sheet pans. The stand shall be fully compatible with, and support, Turbofan Convection Oven models E32D and G32D. Unit shall be supplied in 100% recyclable shipping packaging.

STANDARD FEATURES

- 4 460mm x 660mm / 18" x 26" full size sheet pan capacity
- 4 400mm x 600mm tray capacity
- 110mm tray spacing
- Compact 735mm width
- Digital display time and temperature controls
- Large easy view 20mm high displays
- Electronic thermostat control
- Electronic timer with countdown or time count modes
- Manual mode and Program mode
- 20 programs with 3 stage cooking and stage end alarms
- Core Probe program cooking (optional Core Probe Kit)
- Moisture injection mode (5 levels) and manual injection
- 2 speed bi-directional reversing fan system
- 6.3kW heating power
- Safe-Touch vented side hinged door (standard LH hinge). Optional RH hinge (field convertible)
- Stay-Cool door handle
- Vitreous enamel oven chamber
- Plug-in continuous oven door seal
- Dual halogen oven lamps
- Anti-skid 50mm dia. 76mm high adjustable stainless steel feet
- 4 oven wire racks supplied
- 100% recyclable packaging

ACCESSORIES

- Optional M236060 Core Temperature Probe Kit
- Turbofan SK32 Oven Stand
- DSK32 Double Stacking Kit

E32D4 Full Size Digital / Electric Convection Oven on a Stainless Steel Stand

CONSTRUCTION

Vitreous enamel fully welded oven chamber
Stainless steel front, sides and top exterior
Stainless steel oven fan baffle and oven vent
Removable 4 position stainless steel side racks
Oven racks chrome plated wire (4 supplied)
Stainless steel frame side hinged door
5mm thick door outer glass
5mm thick low energy loss door inner glass
Full stainless steel welded door handle
Stainless steel control panel
Aluminised coated steel base and rear panels

CONTROLS

Electronic controls with digital time and temperature display,
Manual or Program modes
Large 20mm high LED displays
Two individual time and temperature setting control knobs
ON/OFF and Oven Lights key
Fan LO speed key
Timer Start/Stop key
Moisture injection key (5 levels)
Programs select key
Actual temperature display key
Adjustable buzzer/alarm volume
Thermostat range 50-260°C
Timer range from 180 minutes in countdown mode
Timer range up to 999 minutes in time count mode for holding, slow cooking
Optional Core Probe temperature range 50-90°C
Over-temperature safety cut-out

CLEANING

Stainless steel top and side exterior panels
Vitreous enamel oven chamber
Fully removable stainless steel oven side racks
Removable stainless steel oven fan baffle
Easy clean door system with hinge out door inner glass (no tools required)
Removable plug-in oven door seal (no tools required)
76mm high stainless steel feet for easy access underside

SPECIFICATIONS

Electrical Requirements
230-240V, 50Hz, 1P+N+E, 6.5kW, 27A
No cordset supplied
Water Requirements (optional)
Cold water connection 3/4" BSP male
80psi maximum inlet pressure / 20psi minimum inlet pressure

External Dimensions

Width 735mm
Height 730mm including 76mm feet
Depth 810mm

Oven Internal Dimensions

Width 465mm
Height 515mm
Depth 700mm
Volume 0.17m³

Oven Rack Dimensions

Width 460mm
Depth 660mm

Nett Weight (E32D4)
89kg

Packing Data (E32D4)

105kg
0.57m³
Width 760mm
Height 815mm
Depth 925mm

SK32 Stainless Steel Stand

All stainless steel welded frame oven stand for Turbofan E32D and G32D Series ovens
6 position tray runners standard
76mm diameter wheel swivel castors standard with 2 front castors with dual swivel and wheel lock
Welded 38mm and 32mm square tube front and rear frames
Welded rack supports/side frames
Top frame oven supports suit Turbofan E32D and G32D Series oven mounting
Supplied CKD for assembly on site

External Dimensions (SK32 Oven Stand)

Width 735mm
Height 880mm
Depth 650mm

Nett Weight (SK32 Oven Stand)
18.5kg

Packing Data (SK32 Oven Stand)

23kg
0.1m³
Width 830mm
Height 900mm
Depth 152mm

INSTALLATION CLEARANCES

Rear 50mm
LH Side 50mm
RH Side* 75mm
* For fixed installations a minimum of 500mm is required for service

CLEARANCE FROM SOURCES OF HEAT

A minimum distance of 300mm from the appliance sides is required

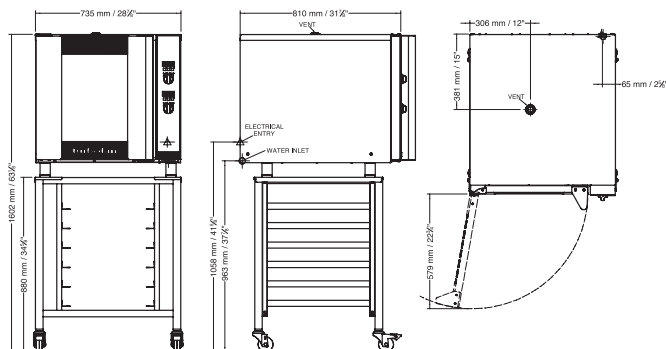

Australia
www.moffat.com.au
New Zealand
www.moffat.co.nz
www.turbofanoven.com

Australia
Moffat Pty Limited

Victoria/Tasmania
740 Springvale Road
Mulgrave, Victoria 3170
Telephone +61 3-9518 3888
Facsimile +61 3-9518 3833
vsales@moffat.com.au

New South Wales
Telephone +61 2-8833 4111
nswsales@moffat.com.au

South Australia
Telephone +61 3-9518 3888
vsales@moffat.com.au

Queensland
Telephone +61 7-3630 8600
qldsales@moffat.com.au

Western Australia
Telephone +61 8-9413 2400
wasales@moffat.com.au

New Zealand
Moffat Limited

Christchurch
45 Illinois Drive
Izone Business Hub
Rolleston 7675
Telephone +64 3-983 6600
Facsimile +64 3-983 6660
sales@moffat.co.nz

Auckland
Telephone +64 9-574 3150
sales@moffat.co.nz



ISO9001
Quality
Management
Standard

Designed and manufactured by



ISO9001

All Turbofan products are designed and manufactured by Moffat using the internationally recognised ISO9001 quality management system, covering design, manufacture and final inspection, ensuring consistent high quality at all times.

In line with policy to continually develop and improve its products, Moffat Limited reserves the right to change specifications and design without notice.

© Copyright Moffat Ltd
AN.TFN.S.1901

an Ali Group Company



The Spirit of Excellence