

REINFORCING CHANNEL I
DETAIL

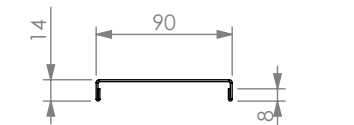

REINFORCING CHANNEL II
DETAIL



REINFORCING CHANNEL III
DETAIL

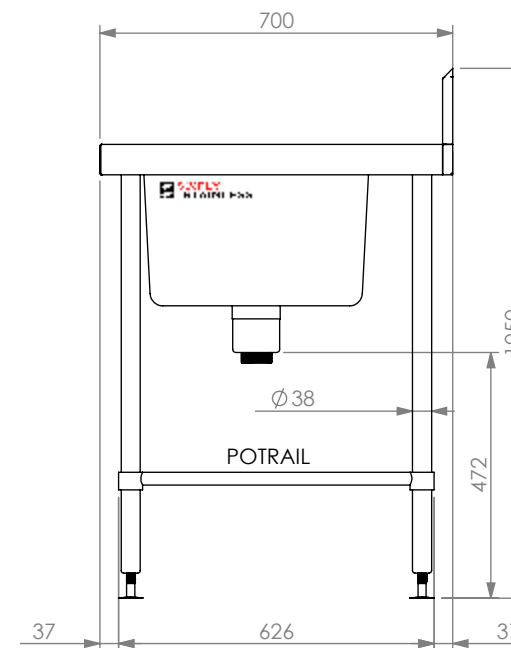
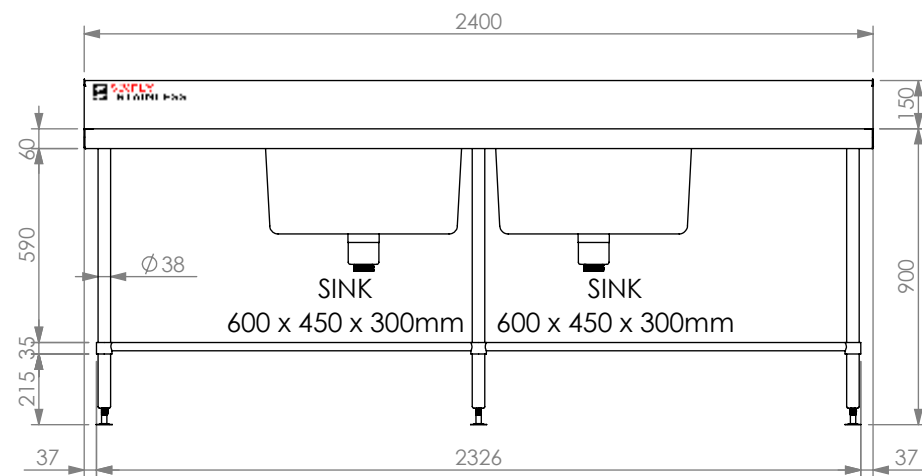
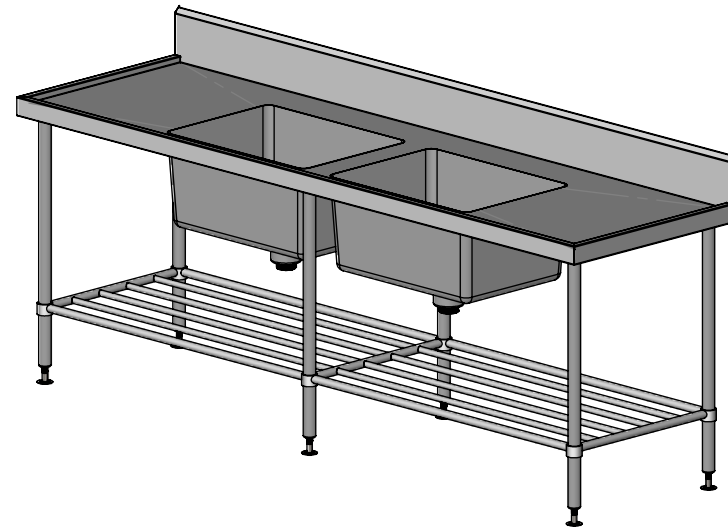

06-7-2400

SIMPLY STAINLESS

www.simplystainless.com
Modular Sinks Tables and Shelving
COPYRIGHT © 2018

This drawing is the property of CI GROUP PTY LTD. Tradings as SIMPLY STAINLESS and it may not be copied, reproduced or modified in whole or in part without prior written permission of CI GROUP PTY LTD. SIMPLY STAINLESS reserves the right to change specification and design without notice.

06-7-2400 DOUBLE SINK BENCH

SCALE : 1:20

CONSTRUCTION NOTES :

1. TOPS MADE FROM 1.2mm STAINLESS STEEL.
2. REINFORCING CHANNEL I & II MADE FROM 1.2mm STAINLESS STEEL.
3. SINKS MADE FROM 1.2mm STAINLESS STEEL.
4. FRAME MADE FROM Ø38mm STAINLESS STEEL TUBE
5. POTRAIL MADE FROM STAINLESS STEEL ROUND TUBE.
6. FEET ARE ADJUSTABLE STAINLESS STEEL DISC SHAPED FEET.